

BRIDGING TELECOMMUNICATIONS AND POWER SYSTEMS ENGINEERING: A COMPUTER-BASED APPROACH FOR STUDENTS

Sohail Anwar
Pennsylvania State University-Altoona College
Altoona, Pennsylvania

Desire D. Rasolomampionona, Ryszard Kowalik, Krzysztof Glik
Warsaw University of Technology
Warsaw, Poland

Abstract

Telecommunication plays an increasingly important role in most of the technological disciplines. Thus, it has become important for the technical specialists in different fields of technology to acquire training and education in the fundamentals of telecommunications. Since the modern telecommunications systems are becoming increasingly dependent on computers for the transmission, reception, and processing of data, it is important to integrate computer-based concepts into telecommunications training and education courses/programs.

This manuscript focuses on the instructional methods, tools, and equipment used to teach computer-based telecommunications fundamentals to the electrical power systems engineering students at Warsaw University of Technology (WUT) in Poland. The laboratory equipment used in the WUT Institute of Power Engineering laboratories allows students to learn the basics of computer-based telecommunications systems using both virtual and hardware-based devices. This telecommunications training begins with the simulation of various telecommunications systems using LVSIM-COM, LVSIM-ACOM, and LVSIM-DCOM computer simulation software. At the end of this training, students' learning advances to a level where they are able to design and implement computer networks, such as, LANs and WANs.

Introduction

A tremendous increase in the use of computer-based telecommunications technology has inspired a similar growth in the telecommunications courses and training programs [1]. The key objective of such education and training programs is to help students develop a working knowledge and basic skills related to the technical aspects of computer-based data communications [2]. These courses generally include training in various topical areas, such as, fundamentals of telecommunications, basic computer networking principles, set-up/configuration of simple computer networks, and the effective use of computer software tools for computer network design and performance analysis [3]. Thus, a traditional telecommunications course begins with amplitude and frequency modulation, proceeding to transmission lines and media, antennas and broadcasting, radio and television, and including a little study material in the topical areas of telephone network, data communications, local area networks, and the Internet. However, as reported in [4], these topical areas, while certainly important, are usually covered in a way that does not allow students to get fully engaged. In a typical introductory telecommunications course, students are taught the above mentioned topics without showing them how they are connected together. Also, there are not many hands-on activities to get the students interested in the field of telecommunications technology. As described in [5], the industrial telecommunications systems are generally

expensive and it is becoming increasingly more difficult for colleges and universities to afford this equipment for their laboratories. One possible solution for this problem is the use of standard software packages to provide students with the laboratory experience in specific telecommunications technologies. These computer simulation packages can be utilized to emphasize selected telecommunications theories. However, a better alternative is described in [6]. This instructional approach emphasizes the use of hybrid laboratories for telecommunications education and training. Such laboratories provide hands-on experience in telecommunications technologies through the use of a suitable combination of basic telecommunications equipment and computer simulation packages.

Realizing the need for an effective training for the electrical power systems engineers in the disciplinary field of telecommunications, the Institute of Power Engineering at Warsaw University of Technology has developed several teaching modules based on the hybrid laboratories approach described in [6]. These modules allow the third-year power systems engineering students to acquire a working knowledge of the telecommunications systems and the computer networking. Using five different types of laboratory stands, students conduct numerous laboratory exercises to learn the key concepts of computer-based telecommunications technology.

Using the first type of laboratory stand, students work with the computer simulation software, LVSIM-COM from LAB-VOLT Company, to learn the functions of oscillators, filters, amplifiers, LC networks, modulators, limiters, mixers, and detectors in AM, FM, PM, SSB, and PLL circuits. This computer software tool allows students to replace all the standard analog communication lab equipment by the images of telecommunications system modules. These computer images can be manipulated by students to perform laboratory exercises. The second Type of laboratory stand uses LVSIM-ACOM from the LAB-VOLT Company. This

computer software tool allows students to perform lab exercises related to AM and FM principles. This laboratory stand uses another software called LVSIM-DCOM which allows students to conduct laboratory exercises related to Pulse Amplitude Modulation (PAM), Pulse Width Modulation (PWM), Pulse Position Modulation (PPM), Pulse Code Modulation (PCM), Differential Pulse Code Modulation (DPCM), Delta Modulation (DM), Amplitude Shift Keying (ASK), and Frequency Shift Keying (FSK). The third type of laboratory stand consists of three computers that are connected together through modems and telephone exchange. This stand is used to conduct laboratory exercises related to remote monitoring and setting of digital protection devices. The fourth type of laboratory stand is used to conduct lab exercises related to the operation of local area networks. The fifth laboratory stand consists of four different personal computers equipped with access points (AP). Using this stand, students learn the working principles of WiFi networks in Adhoc and infrastructure models.

This manuscript describes the hardware and software used by the WUT electrical power systems engineering students to learn the computer-based telecommunications concepts. The laboratory exercises conducted by students are also outlined.

Laboratory Exercises and the Associated Hardware/Software

The equipment used to conduct the lab exercises associated with the above mentioned telecommunications training is housed in three rooms within the WUT Institute of Power Engineering. The following section of this manuscript provides information regarding the hardware/software being used and the associated laboratory exercises conducted by the WUT students.

Room One :

Hardware – Personal computers, function generators, voltmeters, oscilloscopes, and spectrum analyzers.

Software – LIVSIM-COM, LIVSIM-ACOM, and LIVSIM-DCOM

Titles of Lab Exercises – The titles of lab exercises conducted by students using the above mentioned hardware and software are as follows:

- Basic principles of amplitude modulation on the example of double sideband modulation DSB.
- Basic principles of frequency modulation (FM).
- Telecommunication system using amplitude modulation (AM).
- Principles of operation of devices used in a AM communication systems.
- Mechanism for shifting the frequency of primary band used in AM communication.
- Principles of generating modulated signals by AM modulation.
- Determining the percentage of modulation of amplitude modulated signal.
- Reception of AM signals – frequency response RF.
- Principles of operation of mixer.
- Demodulating of AM signal.
- Generating SSB signals using filter method.
- Frequency Shift Keying (FSK).
- The impact of noise on frequency shift keying.
- FSK communication standards.
- Mode 2 of modem CCITT V.23 (1200 b/s).
- Binary Phase Shift Keying (BPSK).
- The impact of noise on Binary Phase Shift Keying (BPSK).

Room Two :

Hardware – Personal computers, hubs, routers, modems, and switches.

Software – Computer Networking Protocols

Titles of lab exercises – The titles of lab exercises conducted by students using the above mentioned hardware and software are as follows:

- Selected communication standards used in power engineering (based on LAN)
- Selected communication standards used in power engineering (based on modems)
- NetBEUI Computer Network Protocol
- TCP/IP Computer Network Protocol
- LAN/WAN networks
- WAN network – Dial-Up and modems

Room Three :

Hardware – Personal computers

Software – COMMVIEW

Lab Exercises Using LVSIM Computer Simulation Software

A brief description of each of the lab exercises conducted using LVSIM-COM, LVSIM-ACOM, and LVSIM-DCOM computer simulation software is listed below:

1. Two-channel function generator.

This lab exercise allows students to use a two-channel function generator and observe simulated signals on the oscilloscope.

2. RMS voltmeter and spectrum analyzer.

During this exercise, students measure amplitude of different electrical signals (with different shape) and examine the relationship between the peak amplitude and RMS values of signals. The spectrum analyzer allows observation of signals in frequency domain.

3. Basic principles of amplitude modulation on the example of double sideband modulation DSB.

This exercise helps students develop an understanding of the key characteristic features of amplitude modulation with using a spectrum analyzer, oscilloscope, RF generator, and other devices.

4. Basic principles of frequency modulation (FM).

This lab helps students in developing an understanding of the principles of generating frequency modulated carrier wave using spectrum analyzer and oscilloscope.

5. Telecommunication system using amplitude modulation (AM).

This lab exercise helps students in developing an understanding of the principles of operation of telecommunications systems using amplitude modulation. By connecting an AM/DSB/SSB generator with a two-channel function generator, students can realize the transmitter scheme. The function of receiving is fulfilled by an AM/DSB receiver. By creating a connection between transmitter and receiver, students can realize a basic telecommunication system, which consists of a transmitter, a telecommunication line and a receiver.

6. Principles of operation of devices used in a AM communication systems.

This exercise helps students develop an understanding of the principles of operation of the AM / DSB/SSB generator and AM / DSB receiver. This exercise is divided into two parts. In the first part; students observe information signal in time domain and in the second part, they observe the signal in frequency domain. The observation of the signal results in answering the question: which parameters affect the shape of the amplitude modulated signal?

7. Mechanism for shifting the frequency of primary band used in AM communication.

This exercise allows students to understand the principle of shifting signal carrying

information to higher frequencies. This operation is done using a mixer, which mixes frequency of data signal (low frequency) with carrier frequency (high frequency). Result values on the outputs of the mixer consist of the sum and difference of input frequencies (low and high frequencies). As a result of such operation, students obtain a frequency band with LSB or USB.

8. Principles of generating modulated signals by AM modulation.

The objective of this exercise is to familiarize students with principles of describing AM modulated signal in both time and frequency domains using the AM/DSB/SSB generator and observing of AM signals using an oscilloscope and spectrum analyzer. During this exercise students analyze the impact of changing amplitude, frequency, modulating index, and shape of the modulating signal on the shape of modulated signal.

9. Determination of the percentage of modulation of amplitude modulated signal.

The objective of this exercise is to familiarize students with the phenomenon of frequency shifting of primary band. Students learn methods to determine the percentage of modulation.

10. Reception of AM signals – frequency response RF.

This exercise allows students to develop an understanding of the principle of operation of RF filter, by creating a simple telecommunications system and by using a spectrum analyzer to observe the frequency response of a filter.

11. Principles of operation of mixer.

The objective of this exercise is to familiarize students with principles of operation of a super heterodyne receiver which uses frequency mixing to convert a received signal to a fixed

intermediate frequency. This can be more conveniently processed than the original carrier frequency.

12. Demodulation of AM signal.

This exercise allows students to develop an understanding of the demodulation process of an AM signal through the use of an envelope demodulator which is located in the AM/DSB receiver.

13. Generating SSB signals using filter method.

One special type of AM modulation is the Single Side Band modulation. The objective of this exercise is to familiarize students with the principles of filters in signal generation using the AM/DSB/SSB generator.

14. Frequency Shift Keying (FSK).

During this exercise, students observe the process of generating and receiving an FSK signal using an FSK modem. Students analyze the operation of the analog and digital loopback. The testing of loopback consists of a test procedure in which the signals from output are sent to their origin. Analog loopback makes it possible to check a single modem. This is why the FSK signal is sent from the modulator output to the demodulator input of the same modem. Students use the FSK modem and can observe spectral effects by changing the relation $\Delta f/R_b$, where Δf is a frequency deviation and R_b is a data transmission speed.

15. The impact of noise on frequency shift keying.

The objective of this exercise is to check if the FSK modem compares the levels of frequency bands and whether the subtraction of levels is a result of carrier signal, noise signal, or a combination of these signals.

16. FSK communication standards.

The objective of this exercise is to familiarize students with the principle of operation of CCITT V.21 and Bell 103 modems during the static mode of operation. Students observe the relationship between control signals, data, and carrier signal.

17. Mode 2 of modem CCITT V.23 (1200 b/s).

The exercise allows students to understand the principles of operation of the CCITT V.23 modem in mode 2 using a static mode of operations. Students observe the relationship between control signals and the data and carrier signal, with an emphasis on the control signals used in the return channel.

18. Binary Phase Shift Keying (BPSK).

During this exercise, students observe generation and demodulation of BPSK signals. Initially, students are familiarized with the BPSK modulation process and with the features of BPSK signals in the time domain. In the next phase, students observe the operation of Phase-locked loop (PLL) in BPSK demodulator. The last phase of the exercise explains features of BPSK signals in the frequency domain.

19. The impact of noise on Binary Phase Shift Keying (BPSK).

This exercise explains the impact of noise on binary phase shift keying and the difference of BPSK, ASK, and FSK signals in response to noise.

Lab Exercises Using Selected Data Communications Standards

These lab exercises use the laboratory stand consisting of three computers that are connected together using modems and a telephone exchange.

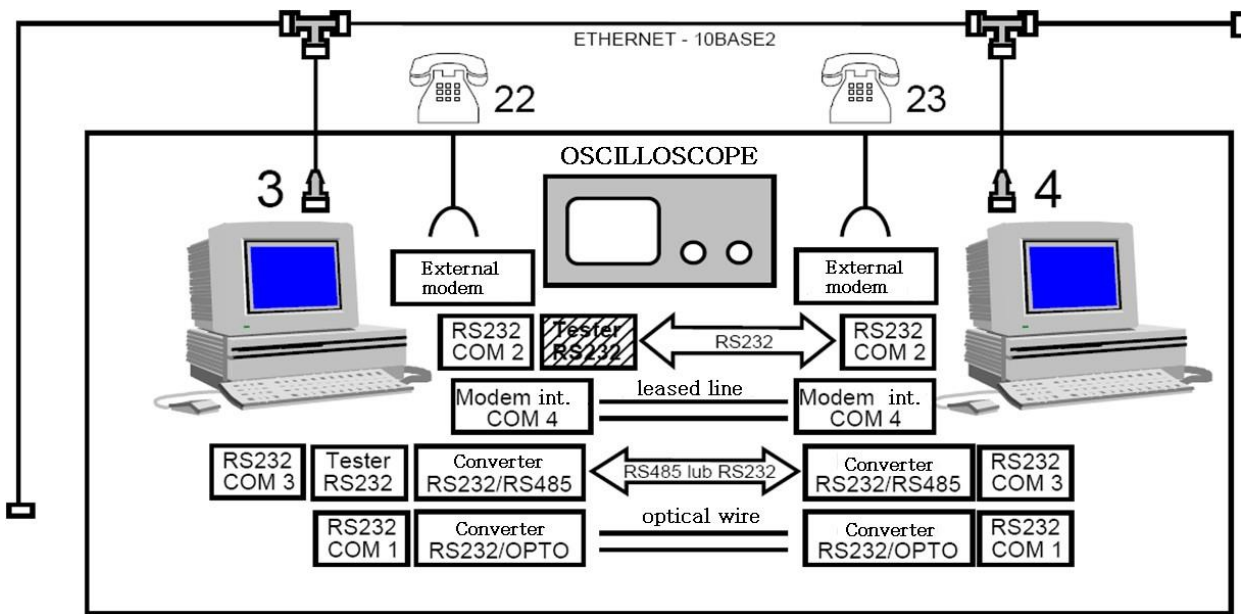

Fig. 1 Block diagram of the laboratory stand – LAN and modems.

Figure 1 shows a block diagram representing this laboratory stand. The laboratory stand is set up to demonstrate the use of telephone systems and modem links for remote monitoring and set-up of digital protection devices, such as, 7SJ device produced by Siemens.

Examples of two exercises conducted by students using the laboratory stand shown in Figure 1 are listed below:

Local Area Network (LAN) – NetBEUI Protocol

Students are introduced to a reference structure of OSI model and with the issues associated with each layer. These layers include physical layer (Ethernet 10/100 Base-T, encoding bit stream, electrical signals in twisted pair wire), data link layer (SCMA/CD, full-duplex, MAC control, auto-negotiation), Ethernet data frame (LLC protocol), network layer and transport layer (NetBEUI), session layer, presentation, and application layer (SMB).

Local Area Network (LAN) – TCP/IP Protocol

This lab exercise introduces students to the data link layer (Ethernet frame, IP addresses),

network layer (internet protocol, IP datagram, ICMP), transport layer (TCP protocol, UDP protocol), application layer (FTP, http, POP, DNS, DHCP, SNMP, SMTP, TFTP), and the subnet.

Lab Exercises Related to WiFi Networks in Adhoc and Infrastructure Models

Figure 2 illustrates the laboratory stand, which consists of three PC computers with Windows 2000 Professional operating system and external Wi-Fi cards (Linksys) with USB 1.1. interface.

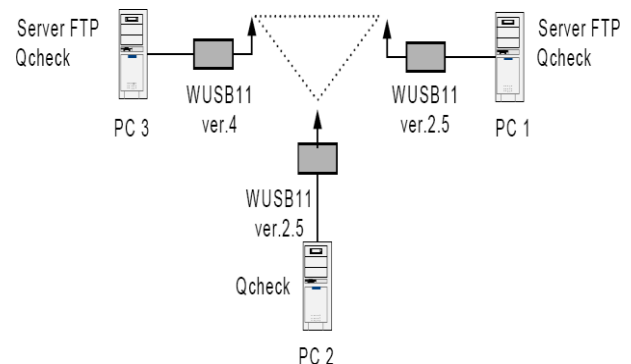

Figure 2: The scheme of network in Ad-hoc model.

Students perform the following tasks using this laboratory stand:

- Install Linksys WUSB 11 (ver. 2.5) cards in the Windows operating system.
- Configure parameters of wireless network.
- Configure Q-check program, which is used to measure performance and capacity of wireless network interfaces.
- Measure delays for different sizes of transmitted packets.
- Measure capacities of transmission (using TCP and UDP protocols).
- Measure capacities for Audio-Video applications (UDP protocol).
- Measure network parameters with enabled WEP encryption.

Figure 3 depicts the laboratory set-up to conduct the lab exercise related to the network configuration in the Infrastructure Model.

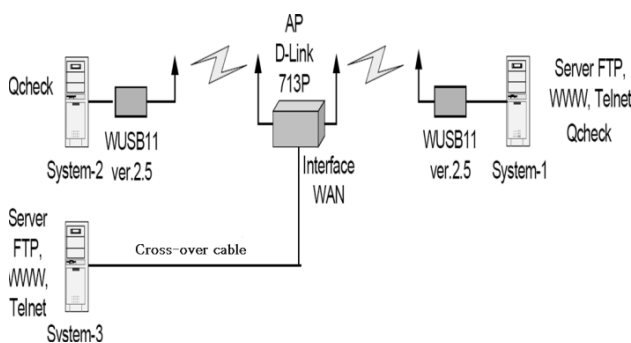

Figure. 3 The scheme of network in Infrastructure model.

This lab exercise is divided into two parts. In the first part, students have to establish a connection using D-Link 713 Access Point and measure capacity of the network using the Q-check program. In the second part, students have to analyze network security options which are available by Access Point. During the exercise, students will use the access point which plays role of wireless gateway.

Students use the DI-713P to properly set up the network connections. It is a wireless wideband router which allows sharing of internet access using a wired (Ethernet) or wireless (802.11b) data transmission technology. The device has a built-in firewall,

which allows the control of data traffic to/from the internet.

Internal network users have access to a built-in DHCP server that provides dynamic IP addresses downloading by stations. In this lab exercise, student perform the following tasks:

- Measure time delay for different size of data packets (Q-check)
- Measure frequencies (A-check)
- Measure frequencies for Audio-Video application (Q-check).

Next, students have to configure a Virtual Server in Access Point as shown in Figure 4. Station System-3 is a client which simulates connections from the Internet and is connected to Access Point by the cross-over network cable to the WAN port. Stations System-1 and System-2 connect with Access Point using wireless interfaces.

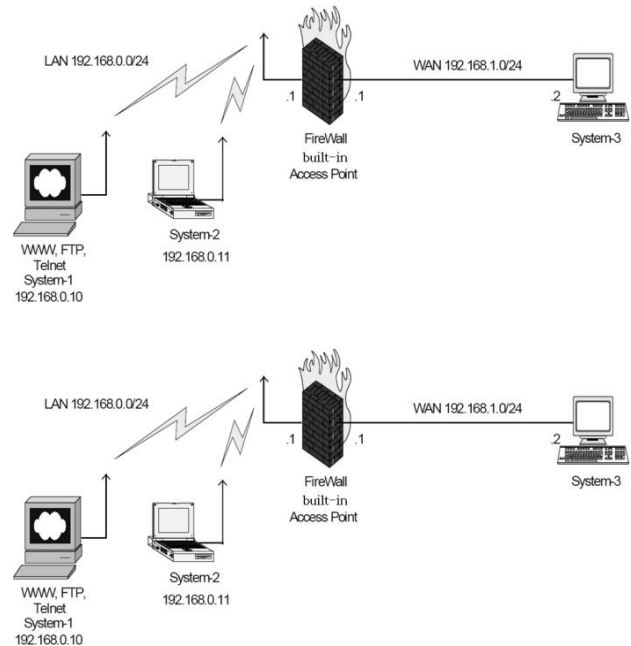

Figure 4: Scheme of network configuration.

In this lab exercise, students need to check:

- Communication between the various stations: System-1 – System-2; System-1 – System-3

- Possibility to connect for any service to System-1 station
- Availability of services from System-2 station
- Possibility to view websites using web browser running on station System-2

Then, students learn to configure access control lists (which work in the third and fourth layers of OSI model) and they configure security options of AP.

In order to realize this task, there is another option created in Access Point – Mac Access Control, which uses mainly MAC addresses of devices in wire and wireless network. In this exercise, students have to configure the security mechanism, according to the following guidelines:

- Station System-2 has to have the possibility to configure Access Point using a www interface and to connect with the services in internet.
- System-1 Access Point station has to communicate only in LAN (both for wired and wireless hosts), but it cannot control through the World Wide Web and connect to the internet.

Assessment of Students' Learning

Different assessment approaches are used to measure and improve students' learning outcomes. The direct assessment methods include written examinations, homework assignments, oral presentations, design projects, and quizzes. The indirect assessment techniques include surveys and questionnaires.

Both direct and indirect assessment techniques can contribute directly to improving students' learning. The students' learning assessment activities facilitate [7, 8, 9]:

- Feedback
- Conceptual Understanding
- Communication
- Student-Faculty Interaction

The direct assessment approach used to measure students' learning in the laboratory exercises consists of the use of assignments, tests, and exams in a closed loop assessment system to allow the lab instructor to better evaluate the performance of students and to determine specifically what changes need to be made to improve the quality of instruction. This assessment process requires development of learning outcomes, the mapping of lab assignments, quizzes, and exams to each of the learning outcomes, and the evaluation of learning data.

Some of the learning outcomes associated with the lab exercises for teaching telecommunications technology concepts are listed as follows:

- Observe and analyze the process of generating and receiving the FSK signal using an FSK modem.
- Observe and analyze the generation and demodulation of BPSK signals.
- Determine percentage of modulation of amplitude modulated signal.
- Use a spectrum analyzer to observe frequency response of a filter.
- Analyze the impact of changing amplitude, frequency, modulating index, and shape of the modulating signal on the shape of modulated signal.

The indirect assessment approach used to measure students' learning in the laboratory exercises consists of the use of an assessment tool which involves qualitative and quantitative survey of students' perceptions about their learning in the lab. Students are asked to rate their perception and understanding of the above mentioned learning outcomes using a Likert scale ranging from 1 (not understood at all) to 5 (very well understood). If a significant number of students indicate a rating of 2 or less on a learning outcome, that topic is revisited during the lab exercises. When a few students indicate a rating of 2 or less on a learning outcome, these students are invited to meet with the lab

instructor on an individual basis for one-on-one help. This learning assessment technique helps the students and the lab instructor to identify areas of weakness in students' learning.

Lessons Learned

The above mentioned indirect and direct assessment methods provided the following information regarding students' learning in the telecommunications lab exercises:

- Students felt that the early material covered in the lab exercises, that is, modulation and demodulation, was a little boring. However, they became more interested in learning telecommunications concepts when the topic of Internet was covered. At that point, the change in student behavior was noticeable. Lab discussions became lively.
- It was noted that the time devoted to networking, including Internet, LANs, and data communications was not enough to develop a solid understanding of these concepts.

The above mentioned problems are now taken care of through the addition of instructional material which shows how the basic telecommunications topics covered earlier in the lab help in understanding the data communications concepts learned later in the course. Also, more lab time is now devoted to the topics related to networking.

Conclusion

This manuscript focused on the instructional approach and the laboratory equipment used by the Warsaw University of Technology to teach telecommunications concepts to the third-year electrical power systems engineering students. These students learn the basic concepts of computer-based telecommunications using both virtual and hardware-based devices. Using five different laboratory stands, students conduct numerous lab exercises to acquire a working knowledge of computer-based telecommunication systems extensively used in the

disciplinary field of electrical power systems engineering. Students are introduced to the techniques used for data transmission in the analog systems and in the digital systems. Students also learn selected standards for asynchronous data transmission used in the local area networks (LANs) and in the wide area networks (WANs). Students also develop network schemes which allow them to explore data transmission in both LANs and WANs. Learning the above mentioned conceptual fundamentals of telecommunications technology helps the WUT electrical power systems engineering students solve computer networking and telecommunications systems problems which they will need to solve during their professional careers in the disciplinary field of power systems engineering.

The assessment of students' learning in the above mentioned laboratory exercises is conducted using direct and indirect methods. The direct assessment methods include written examinations, homework assignments, oral presentations, design projects, and quizzes. The indirect assessment techniques include surveys and questionnaires. Both direct and indirect assessment methods have been used effectively in this lab course to improve students' learning.

References

1. Thain, W. E. and T. Fallon. "A Comprehensive Telecommunications Degree for Engineering Technology." *Proceedings of the 2000 ASEE Annual Conference & Exposition*.
2. McGraw, D. "Getting Down to E-Business." *ASEE Prism*, 10(2), October 2000, pp. 20-24.
3. Refai H. and J. Sluss. "A Laboratory Course for Telecommunications Systems Engineering." *Proceedings of the 2005 ASEE Annual Conference & Exposition*.
4. Fike, J.L. "Teaching Telecommunications: A Networking Approach." *Proceedings of*

the 2005 ASEE Annual Conference & Exposition.

5. Ofosu, W. K. and A. Asgill. "Developing Cost-Effective Laboratory Exercises for Telecommunications Programs." *Proceedings of the 2005 ASEE Annual Conference & Exposition.*
6. Cherner, Y., A. Khan, A. Karim, and G. Mullett. "Simulation-Based Virtual and Hybrid Laboratories for Telecommunications Education." *Proceedings of the 2009 ASEE Annual Conference and Exposition.*
7. Bjorklund, S. and N. Fortenberry. "Measuring Student and Faculty Engagement in Engineering Education." *CASE Report, National Academy of Engineering, 2005.*
8. Bjorklund, S., J. Parente, and D. Sathianathan. "Effects of Faculty Interaction and Feedback on Gains in Student Skills." *Journal of Engineering Education, 93(2), 2004*
9. Kim, H. "Individual Course Assessment as a Core Assessment Tool." *Proceedings of the 2007 ASEE Annual Conference & Exposition.*

Biographical Information

Dr. Sohail Anwar is an Associate Professor of Engineering at the Altoona College of The Pennsylvania State University. In addition, he is a Professional Associate of the Management Development Programs and Services at The Pennsylvania State University, University Park. Also, since 2009, he has been serving as an Invited Professor of Electrical Engineering at the Shanghai Normal University, China. Dr. Anwar is currently serving as the Editor-in-Chief of the *Journal of Engineering Technology* and as the Series Editor of the Nanotechnology and Energy Series, Taylor and Francis Group/CRC Press. Dr. Anwar recently

edited a book titled *Nanotechnology for Telecommunications* published by the Taylor and Francis Group/CRC Press in June 2010. Moreover, he is co-editing a book titled *Advanced Nanoelectronics and Graphene Nanoribbon Technology* to be published by the Taylor and Francis Group/CRC Press in 2012.

Desire Dauphin Rasolomampionona (IEEE M'2005) was born in 1963 in Madagascar. He received his MSc (1988) PhD (1994) and Habilitation (2008) in Electrical Engineering from Warsaw University of Technology (WUT). He joined the WUT Faculty of Electrical Engineering in 1994 at the Power System Protection Division, Institute of Electric Power Engineering. Presently He works as a WUT professor and holds the position of Head of Power System Protection Division. His research interests include protection and control of power system and computer networking.

Ryszard Kowalik was born in 1965. He received M.Eng degree in Electrical Engineering from Warsaw University of Technology, Warsaw, Poland in 1989 and PhD degree from the same university in 1998. He was working for a couple of years as microprocessor devices constructor of and application engineer in power systems and gas industry. His areas of research include power system automation, transformer monitoring and microprocessor/telecommunication technology in power systems.

Krzysztof Glik was born in 1985. He received M.Eng. degree in power system automation from Warsaw University of Technology, Warsaw, Poland, in 2009. He is pursuing a Ph.D. degree at the same university. His areas of research include power system automation and travelling wave fault location in HV lines.