

# FREE BODY DIAGRAMS WITH ANIMATED GIF FILES

Shih-Liang Wang  
Mechanical Engineering Department  
North Carolina A&T State University

## Abstract

A free body diagram (FBD) is a graphic representation in which all connecting bodies have been removed, or the body is “freed” from connecting bodies, to show all forces acting on the body. Drawing a FBD is important in force analysis as it facilitates writing equations of equilibrium of a mechanical system to determine unknown forces and moments. Drawing a FBD correctly is thus an important skill for an engineering student.

Many students have troubles drawing FBDs as there are insufficient examples in the textbooks, especially in the junior and senior level design courses. Over the years, the author has created many FBDs to assist students’ learning. In this paper, the author presents several examples using animated GIF files to guide students to develop FBDs step by step, and these animated GIF files can be easily incorporated in a PowerPoint presentation. Because animation will only work on a computer, screen shots of these animation files are shown in this paper, and the process of creating them is explained.

## Keywords

Free body diagram (FBD), machine design, statics, and animated GIF.

## Free Body Diagrams of Mechanical Systems

A free body diagram (FBD) is a graphic representation of a body (element or segment of an element, sub-assembly, or assembly) in which all connecting bodies have been removed, or the body is “freed” from connecting bodies, to show all forces acting on the body. Drawing a free body diagram can help determine equations of equilibrium of the body in statics to solve for unknown forces and moments.

Textbooks in design of machine elements [1,2,3] provide limited examples in FBDs on gears, shafts, bearings, power screws, bolted joints, and others. One of the reasons for lack of helpful examples is that it has been cumbersome to construct a complex FBD with a CAD (Computer Aided Design) software package in the past. With the advancement of CAD, the task to draw FBDs becomes manageable to instructors. Since the effort can be reused semester after semester, these FBDs become very useful in classroom teaching, as more FBDs are being created.

To help students understand the steps to develop FBDs, the author has used step-by-step figures to show the process of constructing a FBD, and these figures have led to animated GIF files for animated FBDs. Animated GIF files are easy to produce [4], as they are basically stop motion animations consisting of separate figures. Animated GIF files are better than other types of animation, as they are small in file size and are easy to be incorporated in PowerPoint slides and web pages.

The first example in this paper is the FBD of a gear train. FBDs are used to solve unknowns progressively from the input gear, idler pair, and finally the output gear. The animation is intended to show the progression of drawing these related FBDs. The second example is the FBD of a bolted joint. This example is intended to show the relation between internal forces on the bolt, nut, and clamped members: the tension on the bolt and the compression on the clamped members are equal and opposite. The next two examples (a c-clamp and a vise grip) are to illustrate the FBD of a power screw which transmits axial force and torque.

The last example is of a bevel gear on a shaft to show FBDs in assisting drawing shear force and bending moment diagrams. Finding the maximum moment along a shaft is important to identify the critical point of the shaft for the maximum stress.

However, many students have trouble drawing these diagrams. This animated FBD is intended to help student understand the process by showing the progression from one end of the shaft to the other end.

### **FBD in a Gear Train**

In an earlier paper [5], the author has given several examples on how to determine the direction of gear forces of different types of gears. In this paper, the focus is on the process of drawing FBDs in a gear train. In Figure 1, a double reduction gear train is shown with the direction of rotation labelled. An animated GIF is created to show the steps to create the FBD of the input gear, idler pair (gears 3 and 4), and output gear.

The 1<sup>st</sup> step is to draw a FBD of the input gear, as shown in Figure 2. The tangential component of the gear force  $F_{32}^t$  will be in the direction that will create a torque opposite to the input torque so that the sum of torques is equal to zero. The direction of the radial component of the gear force  $F_{32}^r$  is toward the gear, as shown in the Figure.

The next step is to draw the FBD of the idler pair (gears 3 and 4). These two gears are on the same shaft and can be treated as one body with one FBD. The tangential component of the gear force at the pitch point on gear 3,  $F_{23}^t$ , is in the direction opposite to the force acting on gear 2,  $F_{32}^t$ , based on Newton's 3<sup>rd</sup> Law.  $F_{23}^t$  is then the known value in the FBD of the idler pair. Next, we can draw the gear force at the pitch point on gear 4. The tangential component of this gear force  $F_{54}^t$  is in the direction that will create a torque that balances the torque created from  $F_{23}^t$  on gear 3, as shown in Figure 4.

The process then continues on to the last gear, gear 5. These three separated FBDs are shown in Figure 4. Note that the separated gears are kept in the same relative orientation and positions, similar to an exploded view of an assembly, which shows parts of an assembly while maintaining relative orientation and positions in the assembly.

The animated GIF provides the progression of drawing FBDs: starting from the 1<sup>st</sup> FBD where

input force/torque is given till the last FBD where the output torque and reaction forces are solved. Altogether, there are 10 figures in the animation to explain the process. Only 4 figures are shown here due to the space limitation.

### **FBD of a Bolted Joint**

In Figure 5, a bolted joint consists of two members fastened by a bolt and nut. Once the bolt is tightened, the members are subjected to compression and the bolt is subjected to tension. Figure 5a shows the bolted joint, and there are no external loads to separate the bolted joint. There are, however, internal forces on the bolt, nut, and members. These internal forces will appear only when we draw separate FBDs – one for the bolt and nut, and the other for the clamped members, as in Figure 5b. In Figure 5c, the two FBDs are further separated. This animation is intended to show the relations between internal forces on the bolt, nut, and clamped members.

### **FBD of Power Screws**

The next two examples (a C-clamp and a vise grip) are to illustrate the FBD of a power screw which transmits an axial force and torque. Figure 6 shows the input and output force on a C-clamp. The axial force and torque on the power screw is not obvious until separate FBDs are drawn, as in Figure 7. Similar figures on a vise grip are shown in Figures 8 and 9. These two examples help students to visualize the torque and force on a power screw, and understand that the torque applied to the handle is equal to the torque applied to the screw.

### **FBD to Determine Internal Shear Force, Bending Moment, and Torque Along a Shaft**

In Figure 10, a bevel gear train is shown, and the FBD of the input shaft with the bevel gear is shown in Figure 11. This example is to show FBDs in assisting drawing shear force and bending moment diagrams of this shaft. Finding the maximum moment along a shaft is important to identify the critical point of the shaft - the location of the maximum stress.

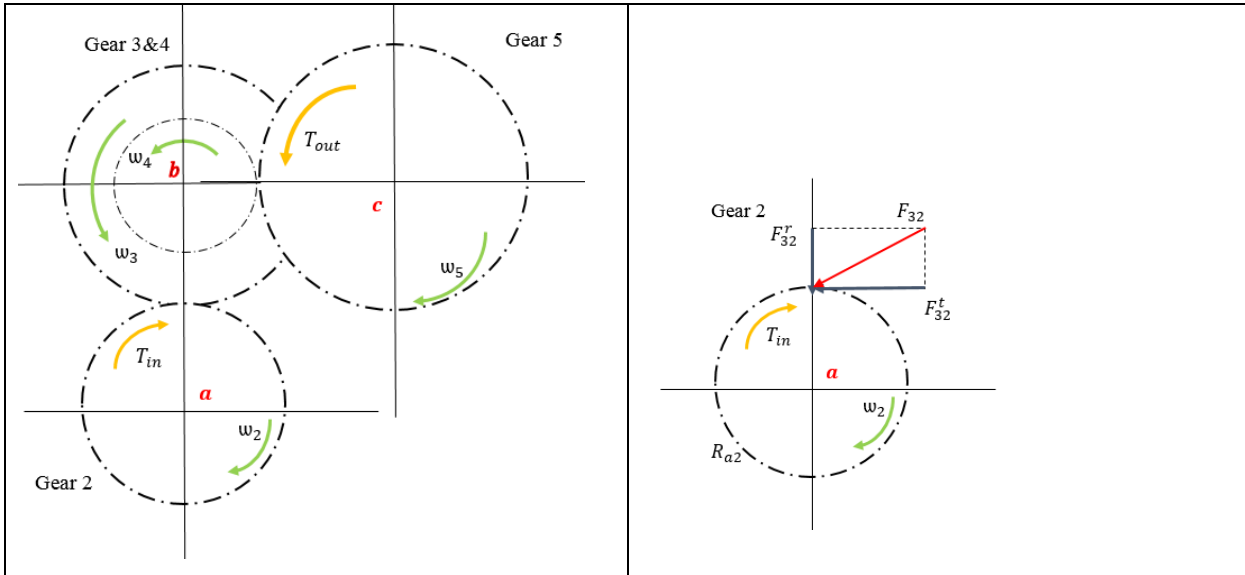

Figure 1: A double reduction gear train, with input and output torques shown.

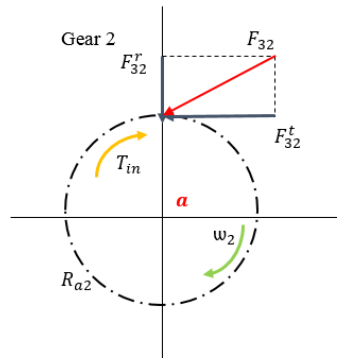

Figure 2 : FBD of the input gear.

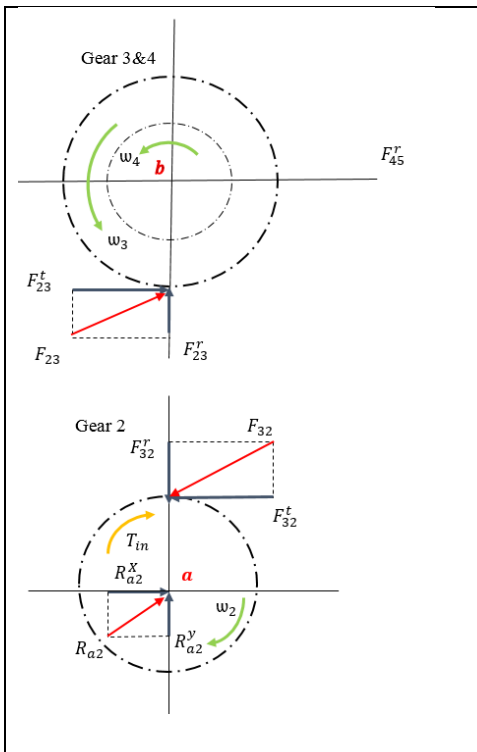

Figure 3: FBD of the input gear and the idler pair (gear 3 and 4).

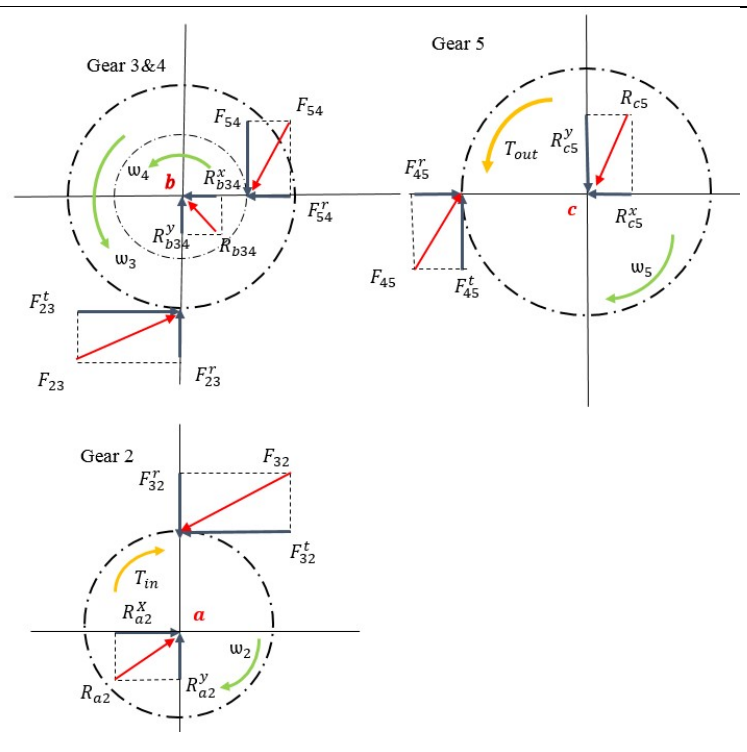

Figure 4: FBD of a gear train, with the input gear, output gear, and idlers separated.

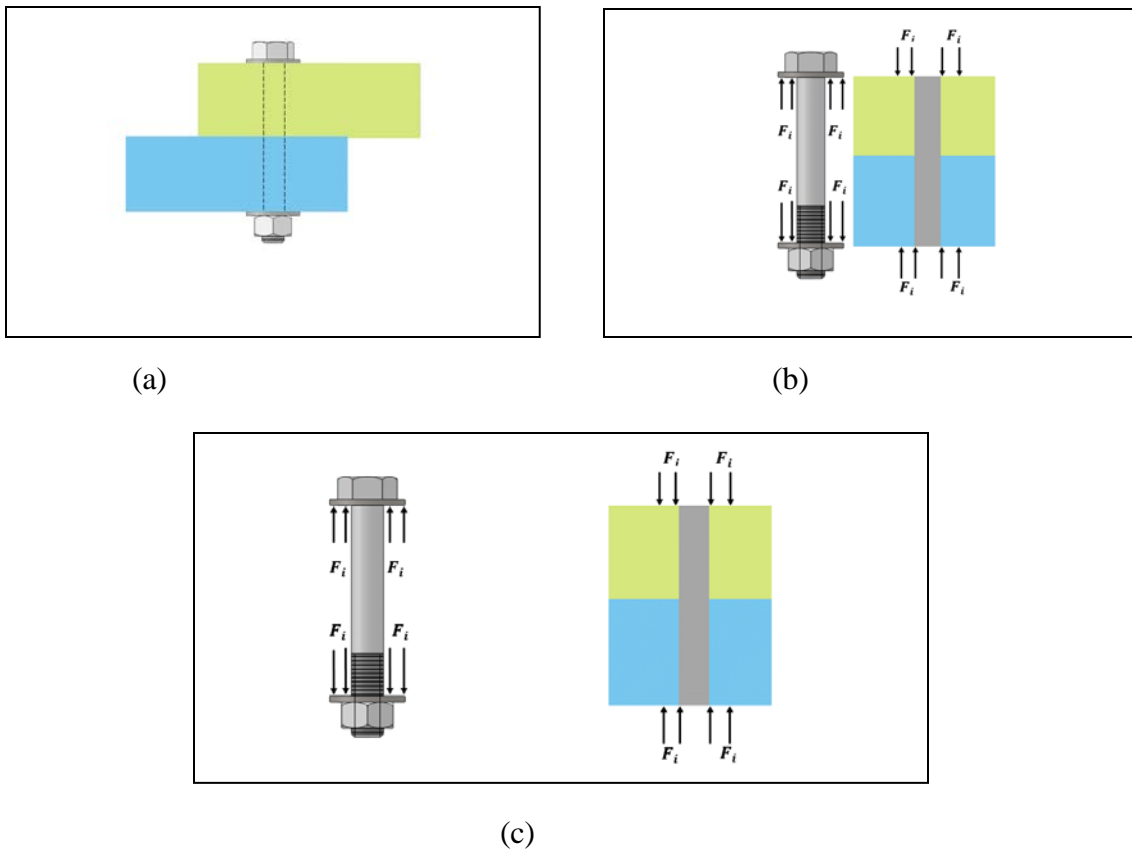

Figure 5: A bolted joint – FBD of the bolt, nut, and clamped members.

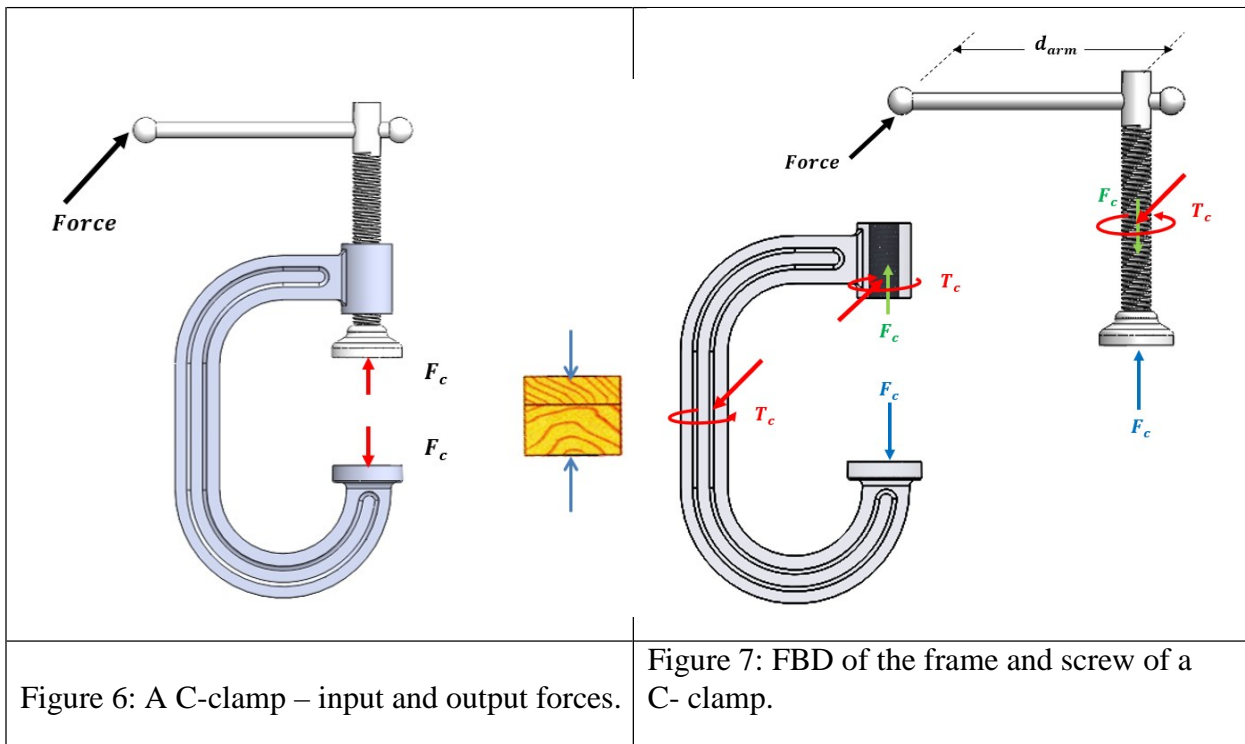
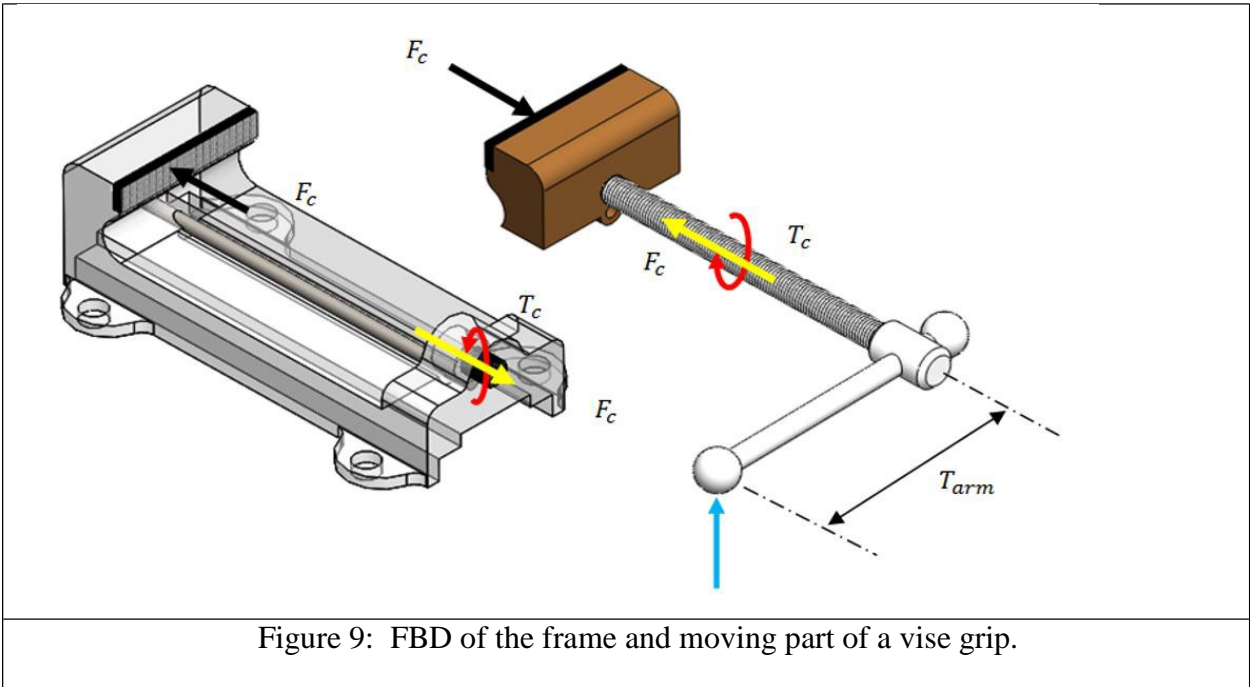
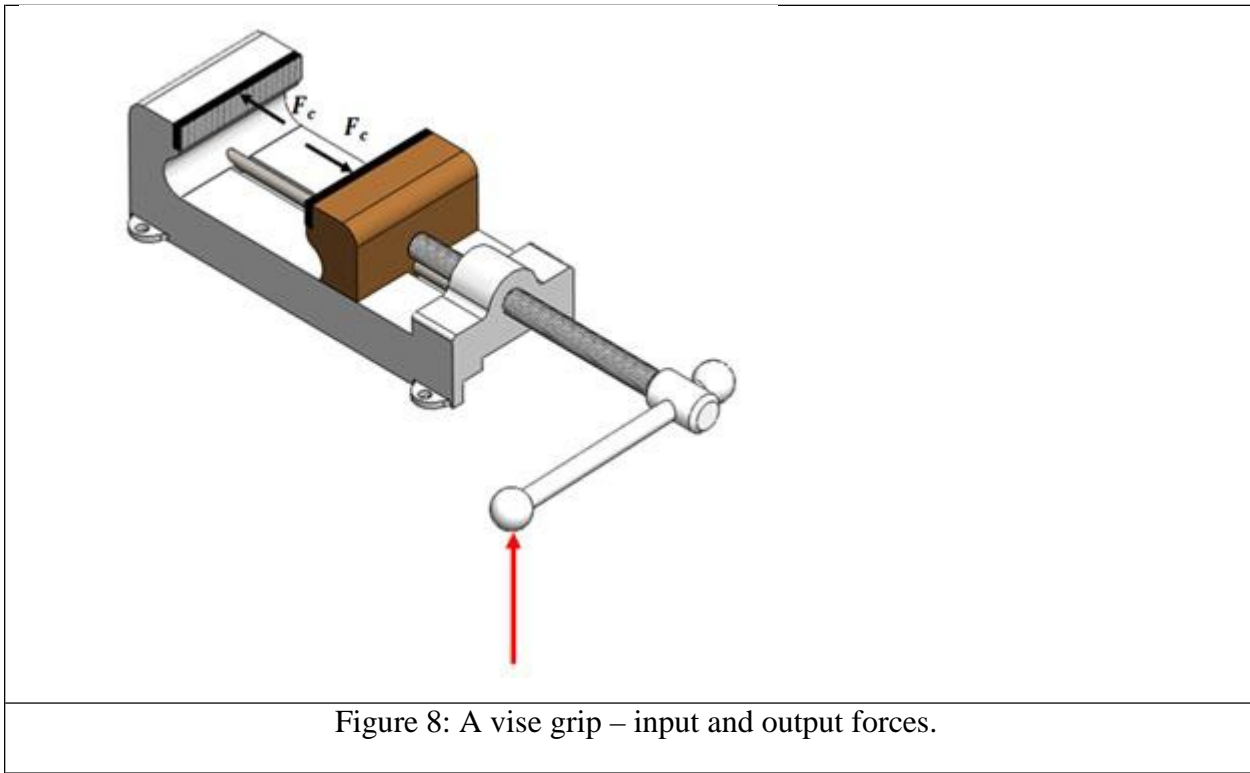
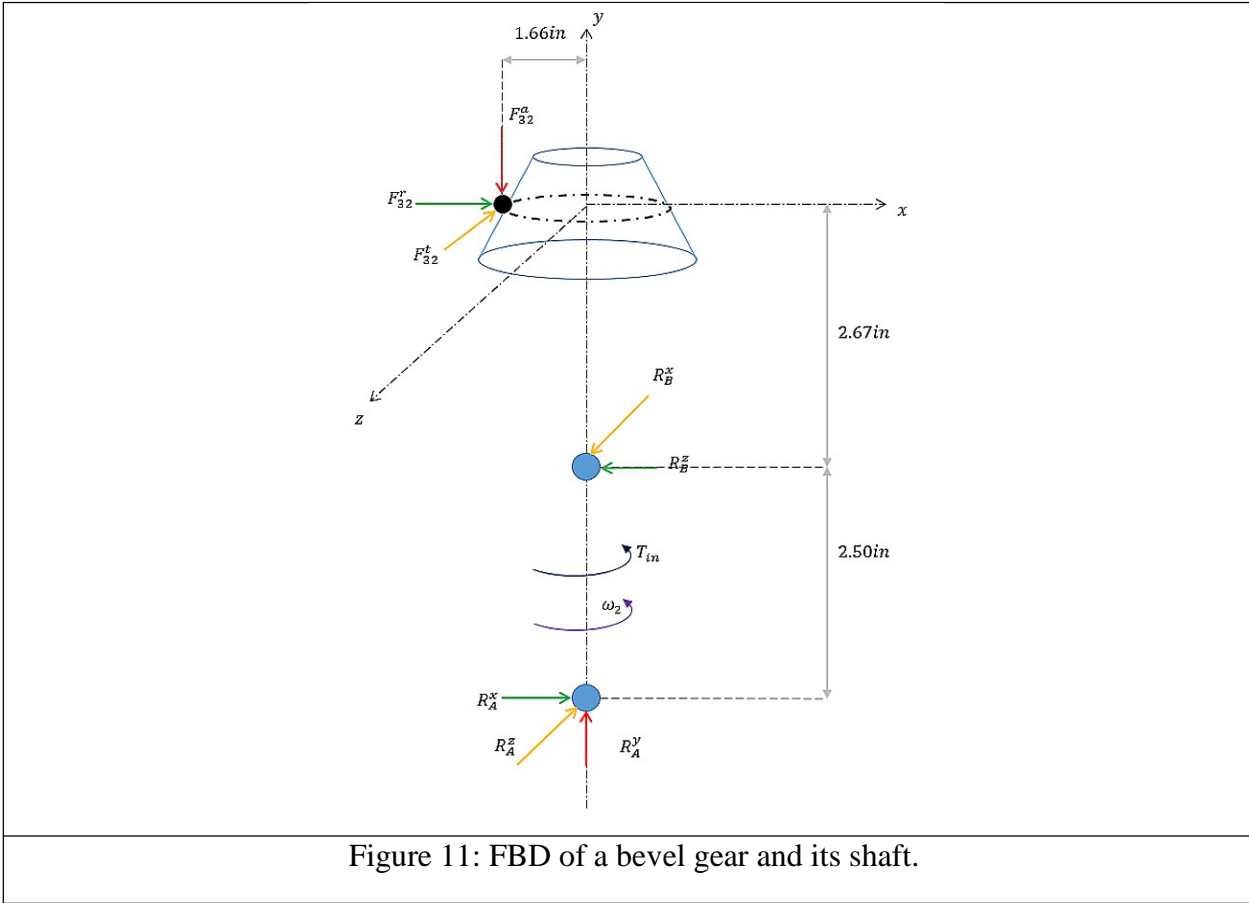
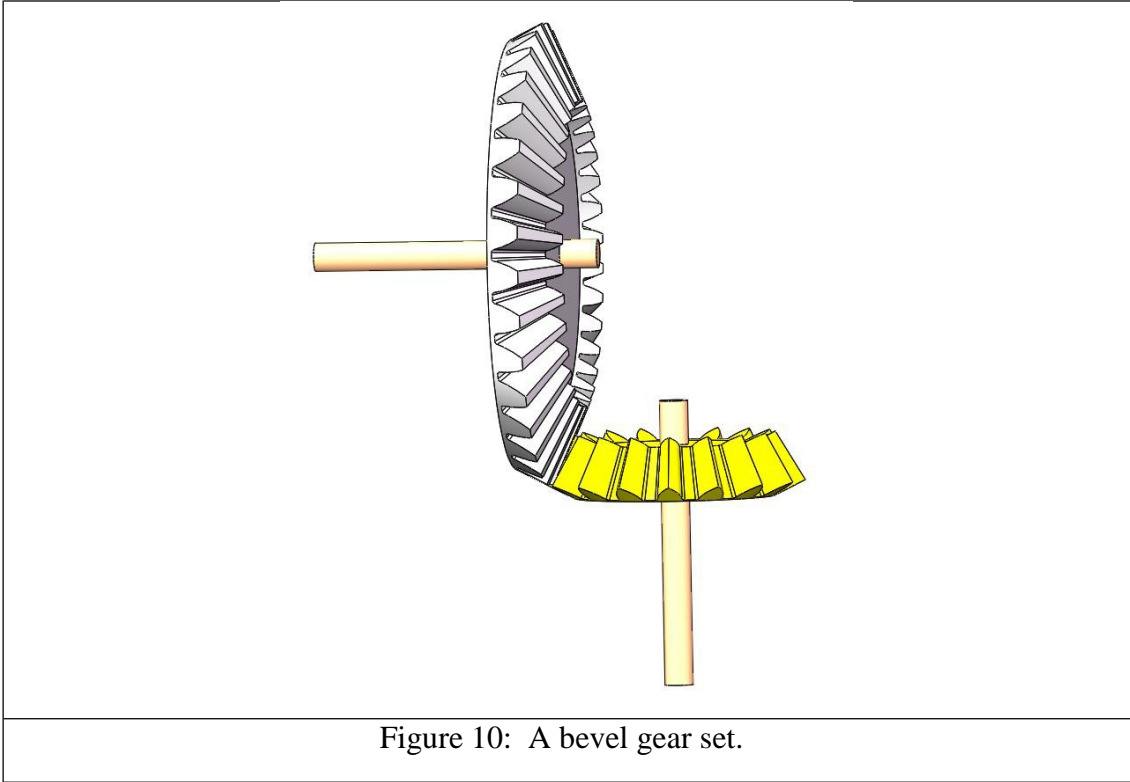

Figure 6: A C-clamp – input and output forces.

Figure 7: FBD of the frame and screw of a C-clamp.





To draw the shear force and bending diagrams of the shaft, we can lay the shaft horizontally and treat it as a beam. From left to right along the shaft, we can make "hypothetical cuts" before and after each reaction/load. At each cut, we can calculate the magnitude of internal shear force and internal moment from the FBD using associated equations of equilibrium. As the process progresses, the shear force and bending moment diagram can be drawn. Four of these FBDs are shown in Figure 12 with different places of "cuts."

Once the shear force and moment diagrams are constructed as in Figure 13, one can check the relationship between the shear force diagram and moment diagram. The moment diagram is a visual representation of the area under the shear force diagram. The torque diagram is also shown in this figure, and the internal torque can be calculated using the same "hypothetical cut" technique

### Concluding Remarks

This paper highlights some GIF animation files used in the author's lecture in a junior/senior level design course on machine elements. The author believes that more examples of FBDs, especially those animated ones, can help students acquire and master the skill/knowledge in drawing FBD.

An animated FBD is valuable as it shows the process of generating FBDs, not just showing the final results. It has the same effect as drawing free-hand sketches on the blackboard/whiteboard from scratch, except that it is neater and with multiple colors, and computer files can be easily replayed again and again. It is still time consuming to prepare these animated FBDs, but these animated GIF files improve students' comprehension. All 3D models shown in this paper are made with CAD Software SOLIDWORKS [6] and the rest of the sketches are made with Microsoft Word's built-in drawing tools.

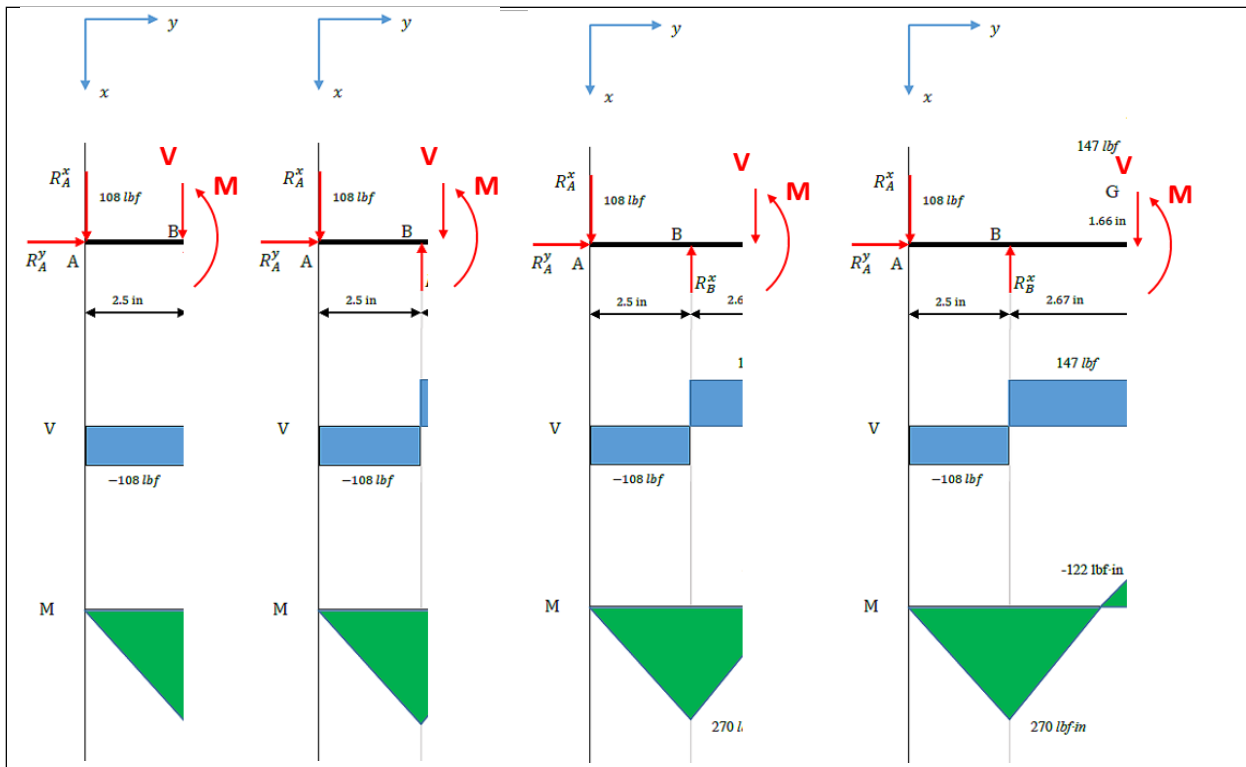
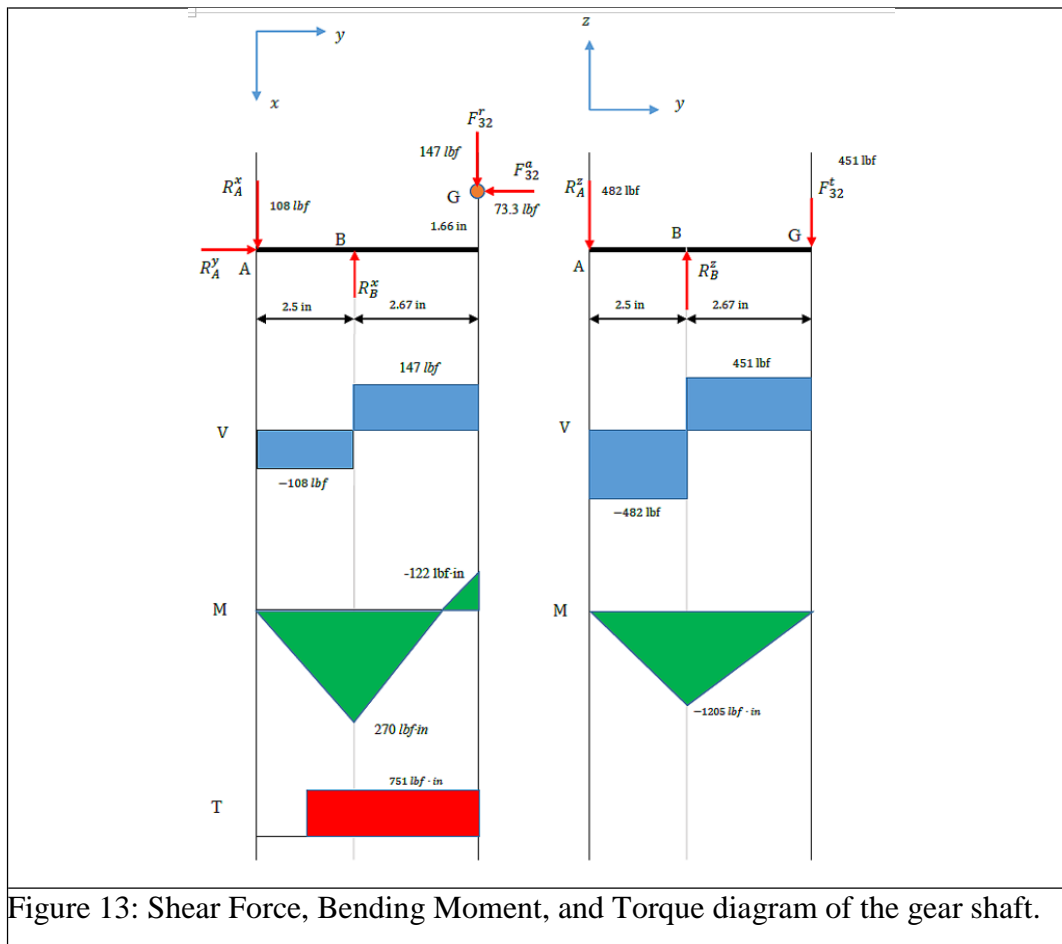

Figure 12: Progressive development of the shear force and bending moment diagram.



## References

1. R. Budynas and J. K. Nisbett, "Shigley's Mechanical Engineering Design", 10<sup>th</sup> ed., McGraw-Hill, 2014.
2. R. L. Mott, "Machine Elements in Mechanical Design", Prentice Hall; 5<sup>th</sup> ed., 2013.
3. R. L. Norton, Machine Design: An Integrated Approach, 5<sup>th</sup> ed, Prentice Hall, 2013.
4. How to animate GIFs with Microsoft GIF Animator, <http://gwanderson.server101.com/Computer101/gifAnimate.htm>
5. Wang, S-L., "Free Body Diagrams of Gear Trains," in CD Proceedings of 2008 ASEE Zone 1 Conference, West Point, NY, March 28-29, 2008.

6. SolidWorks, <http://www.solidworks.com/>

## Biographical Information

Shih-Liang (Sid) Wang is a Professor of Mechanical Engineering at North Carolina A&T State University.