

# DISTRIBUTED COLLABORATIVE DESIGN AND MANUFACTURE IN THE CLOUD — MOTIVATION, INFRASTRUCTURE, AND EDUCATION

Dirk Schaefer<sup>1</sup>, J. Lane Thames<sup>2</sup>, Robert D. Wellman Jr.<sup>3</sup>, Dazhong Wu<sup>1</sup>, and David W. Rosen<sup>1</sup>

<sup>1</sup>George W. Woodruff School of Mechanical Engineering,  
Georgia Institute of Technology

<sup>2</sup>School of Electrical and Computer Engineering  
Georgia Institute of Technology

<sup>3</sup>Information Technology, Professional Education  
Georgia Institute of Technology

## Motivation

The Internet, the World Wide Web, and Globalization are continuing to induce new paradigms of enterprise business models and product realization processes. Fierce competition, unprecedented rates of technological discovery and development, instantaneous delivery of information via Internet communication technology, immeasurable amounts of data, and ever-increasing complexity of engineered systems and their designs coupled with an unquenchable thirst to minimize time-to-market while maximizing quality-of-product. These are just a few factors driving an evolution in the globalized product supply-demand ecosystem and their associated industries and enterprises. It is now common for people from all walks of life from around the globe to work together seamlessly using Web-based technologies and its associated communication frameworks such as, social networking, online/on-demand multipoint video tele-collaboration, Voice-Over-Internet-Protocol (VoIP), instant messaging, digital communities, virtual worlds, and many more. These technologies have facilitated game-changing paradigms such as globalization, mass collaboration, mass customization, as well as new technologies such as cloud computing and virtualization. These technologies provide capabilities for real-time communication using devices ranging from smart-phones and personal digital assistants to laptops and desktops. The Internet-based information and communication technologies (ICT) listed above have also provided mechanisms for radically new methods of innovation, engineering, design, and

manufacturing that could not have even been imagined just a few years ago. In particular, the ideas of mass collaboration, distributed design, and distributed manufacturing fueled by the Internet are now realizable *methodologies* for the next generation of product design and manufacture. The methodology, which we refer to as *Collaborative and Distributed Design and Manufacturing (CDDM)*, can encompass the entire spectrum of product lifecycle that revolves around the product manufacturing process. This product lifecycle spectrum includes product conception, design, comprehension, analysis, synthesis, simulation, prototyping, and physical manufacturing. This is not to say that the “Internet” and the “Web” can actually *perform* these processes. Instead, the Internet and the Web provide the ICT infrastructures and technologies, which *bind* together the necessary components of the underlying manufacturing lifecycle infrastructure components needed for the processes. CDDM provides significant economies of scale, reduced time to market, and many other features that can significantly benefit organizations involved in the manufacturing process.

Many traditional enterprises that specialize in the design and manufacturing of products follow a model based on *vertically integrated* business units. As such, homogenous engineering design groups and their silos of isolated design processes reside within this ‘vertical stack’ of business units. Modern day products, however, are highly integrated complex systems of cross-layered and cross-domain technological families. As a result, cross-disciplinary engineering design is required and must be

incorporated into the product realization process. To achieve this requirement, isolated silos of engineering design processes must be merged (integrated) into heterogeneous interdisciplinary engineering design units.

One characteristic of a vertically integrated enterprise (VIE) is that most, if not all, aspects of the enterprise are ‘under one roof’. The VIE’s product families are designed, developed, manufactured, sold, and distributed by assets owned by the enterprise. However, products in many domains have become increasingly complex and technologically sophisticated, in both their design and manufacturing. Capital expenditure required for product realization of diversified VIE product portfolios can become prohibitive. This happens when product families based on technology advance at very fast rates, i.e., the semiconductor industry and computer chips. As a result, the VIE is becoming more and more an exception to the rule. Instead, the common enterprise of today—the Globalization 3.0 enterprise, or G3E—is based on ideas of IP-centricity (intellectual property centric), strategic partnership, mass collaboration, mass customization, fabrication-less product realization, distributed design, distributed manufacture, distributed assembly, distributed product distribution, etc. G3 has enabled enterprises characterized by geographically separated ‘assets’—geographically separated human, physical and virtual resources. In the near-tomorrow, the idea of design-by-collective-intelligence may be a common design methodology, driven by crowd-sourced design, mass collaboration and mass customization. Instead of vertically integrated enterprises, fuzzier supply-demand chains are expected to emerge and the idea of virtually integrated product (VIP) families will dominate. A VIP family is realized via the horizontal integration of design expertise—subject matter experts within a collection of independent enterprises forming strategic partnerships and combining resources to achieve a common outcome, which, in this scenario, is the realization of products. G3E product realization will require a transformation of existing cross-disciplinary engineering design and design integration technology. The original research questions, goals, objectives, and hypotheses of cross-disciplinary design integration will inspire more advanced variants where cross-disciplinary design integration needs to happen across enterprise boundaries. Cross-disciplinary design integration

will not only cross enterprise boundaries, the boundaries will exist in the so-called ‘Cloud’. In essence, future engineering design and manufacturing processes will be cross-disciplinary and cross-enterprise and it will be enabled, or at least significantly supported by the Cloud. Consequently, researchers and practitioners from industry are [18] continuously looking for more effective and efficient ways of product design and manufacturing, which can help engineers capture and reuse information and knowledge as well as, help managers ensure the coherence of various engineering and business functions across internal and external organizational collaborations. As a result, it is our thesis that a cloud-based design and manufacturing paradigm for future product development and realization processes is needed.

While the preceding has been portrayed mainly from the perspective of cutting-edge research under the umbrella of advanced design and manufacturing, it is also very important to infuse an appropriate dosage of our research into our educational activities and expose our students to latest developments in the field. Consequently, we have embedded our architecture for cloud-based design and manufacturing as well as related tools into one of our graduate level engineering design courses. A key element of this course is a design and manufacturing related open ended problem. This problem is to be tackled by a group of approximately 30 students located at various locations across the country, utilizing – among other things – the concepts of crowd sourcing, mass collaboration, and cloud-based design and manufacturing. An overview of this endeavor is presented in the final section, following a detailed technical discussion of our integrated infrastructure for cloud based design and manufacturing.

### **The Cloud Computing Paradigm — An Overview**

In this section, we present an overview of cloud computing technology and its inherent characteristics that motivate its use for distributed and collaborative design and manufacture for both the industrial and education sectors. Cloud Computing is a highly topical Information Technology (IT) paradigm that is anticipated to significantly impact the way business will be conducted in the future [1, 2]. While the concept of cloud computing was originally developed in the

1960s, it was only a few years ago that it became a feasible aspect of day-to-day IT infrastructures due to the availability of the Internet and other recent advancements in information and computing technologies.

Unfortunately, a unique definition for cloud computing does not currently exist as academics, industrialists and government agencies have tried to wordsmith its meaning depending on their respective interests, roles and goals [3, 4]. In essence, cloud computing is concerned with delivering computing as a service rather than a product, whereby shared resources, software and information are provided to computers and other devices as a utility over a network. In other words, it is a fancy marketing term for networked computers that provide services (or resources) through the Internet to a network of clients who utilize them [5].

Currently, the three most prominent tiers characterizing cloud computing, which are abstractly illustrated in Figure 1, are software as a service (SaaS), platform as a service (PaaS), and infrastructure as a service (IaaS). These three tiers of service are technologically achievable because of the ubiquity and reliability of Internet communications, advanced Web 2.0 features, reduced cost of enterprise-class server systems, and other ancillary technologies such as software-based machine and network virtualization.

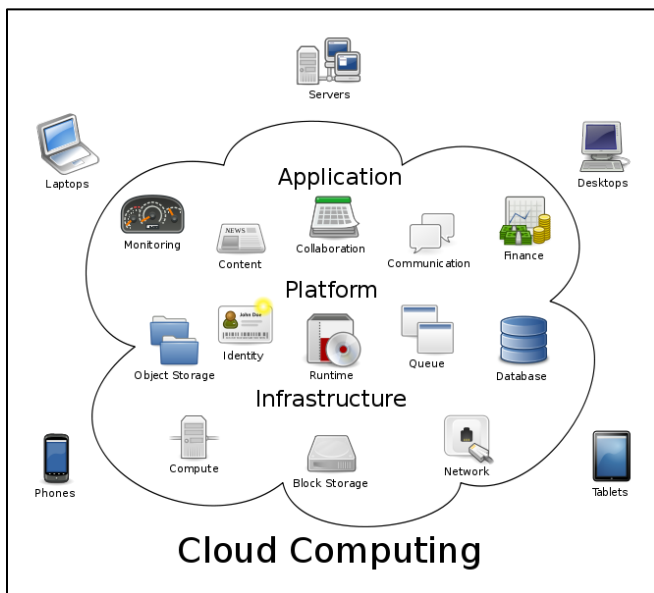

Figure 1: Cloud computing service tiers. [6]

Software, as a service, provides customers with access to software applications over the internet and, hence, eliminating their need to install and run software on their own computers. The two main advantages of this approach are to save cost by choosing a pay-as-you-go model over the cost of purchasing full software licensing, and to eliminate downtime for software maintenance and support. Platform as a service provides customers with an entire computing platform comprised of cloud infrastructure and cloud applications. That way, it facilitates the deployment of applications without the cost and complexity of buying and managing the required hardware and software layers. Infrastructure as a service typically provides customers with a platform virtualization environment along with storage and networking capabilities. Instead of purchasing servers, software, and network equipment, customers rent these resources as a fully outsourced service on a pay-as-you-go basis.

The now demystified cloud can be *public*, *private* or a *hybrid* in nature. In other words, companies (or customers) may choose to implement their own internal cloud as a local area network (private cloud), use the cloud infrastructure from a third-party provider (public cloud), or opt for a hybrid – for example, to rent and run software-as-a-service in the public cloud and store application data in a local, private cloud (see Figure 2).

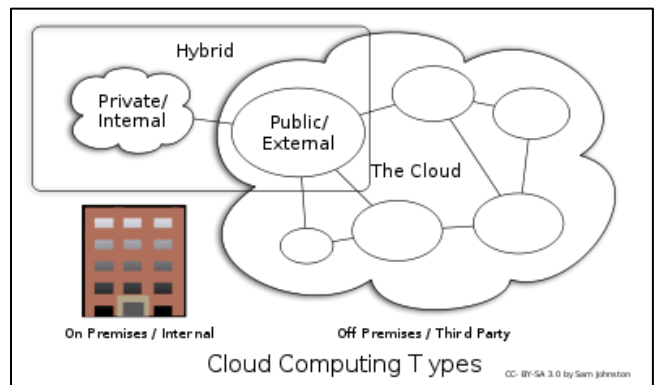

Figure 2: Private, public, and hybrid clouds. [6]

Currently, SaaS is the most widely used cloud computing application, followed by PaaS and IaaS. Since cloud computing is still in its infancy, it is not surprising that, at present, it is most widely utilized within the IT sector. However, other industry sectors have started to realize its potential on a larger scale and significant ramifications are anticipated. For example, Narasimhan and Nichols [12] along with

Itracks, an online market research firm, surveyed 155 companies with experience using cloud computing technologies and found the following statistics: (1) Sixty percent of survey respondents prefer cloud technology over on-premise implementations, and (2) Sixty-eight percent plan to have a large proportion of the applications deployed within public clouds within 3 years of the survey. Other statistics and data are available in their paper [12]. One particular cloud computing application that has begun to emerge is the paradigm of cloud-based design and manufacturing, which is addressed in the following section.

### **Cloud-based Design and Manufacture (CBDM)**

Most recently, cloud computing has made its advent into the domain of computer-aided product development [5, 6, 7]. As a first step in this direction, companies consider replacing their own Computer-Aided Design (CAD) software licenses with CAD software as a service in the cloud [5]. Running a CAD package on a provider's server(s) through the cloud and paying a small fraction of the original license fee on a pay-as-you-go usage basis is certainly appealing. In addition, time and cost intensive software updates and maintenance issues are out of the picture as well. On the downside, it is obvious that an internal local area network connection allows significantly faster data transfer rates than an Internet connection. In addition, rendering CAD data can be very demanding in terms of computing power and over the Internet one may experience a slight lag in response time. Whether or not the lag is tolerable will depend on the various usage scenarios. While it may be perfectly acceptable in a CAD training environment, rendering delay due to lag may be annoying (and costly) in day-to-day full scale design operation. In practice, currently most companies choose speed over cost and prefer to run their software locally. One way of minimizing the response lag is to store CAD data and software on the same server. The less data one needs to transfer through the cloud, the better (and faster/cheaper). In light of this and as alluded to in Section 1, it becomes apparent that providing/renting storage space as a service through the cloud is yet another interesting business model to consider. Pay-as-you-go rates for data storage may be significantly cheaper than purchasing your own hard disc drives and, similar to the SaaS case, hardware maintenance and replacement are no longer an issue. An important issue related to such

cloud computing services is that of data security. Not knowing exactly where in the cloud sensitive data is stored and what is going to happen to it in case of a black-out or server crash is a major concern for any company. However, the overall risk of losing data is relatively small. Major, well established providers of cloud-based services usually clarify all data security and IP related aspects in their terms and also provide testimonies of high-caliber clients with highly confidential data.

In addition to CAD software as a service, other business-related 'everything-as-a-service' models have started to emerge [13]. The same trend will also be seen within the 'mobile Internet', which will be one particular communication platform that utilizes ubiquitous cloud computing technology for mobile 'smart phone' applications along with mobile devices actually offering cloud services such as data collection, i.e., smart phone sensors. For example, Morgan Stanley [14] claimed that the number of mobile Internet users could be 10 times larger than the number of personal computer Internet users.

While computing and information technology is undergoing a seismic paradigm shift from the traditional client/server model to the enhanced cloud computing model, design and manufacturing communities are beginning to consider aspects of cloud computing. A number of companies, including Autodesk and Fujitsu, are attempting to implement this model. For example, Autodesk claims that they are able to provide their customers with greater access to design and engineering documents anywhere and anytime [19]. Some of the featured services include: (1) Cloud rendering, providing customers with powerful rendering capabilities so as to have better visualization of 3D models; and (2) Software-as-a-service, helping designers to exchange information securely so as to enhance effectiveness and efficiency of team collaboration. Another example is Fujitsu and its engineering cloud, which makes it possible to efficiently consolidate applications and high-volume data formats. Their engineering cloud provides a high-speed 'thin client' environment, server consolidation and license consolidation [20].

One particular and emergent paradigm currently being investigated [21] is related to manufacturing and aims to explore the potential of extending the cloud computing model to physical resources such as 3D printers for distributed and Internet-enabled

additive manufacturing machines such as, mills, lathes and other manufacturing-related resources. Long-term, computer-aided product development in general (including design, analysis and simulation, as well as manufacturing) is expected to become predominantly cloud-based. It is considered a new model to aid future globally distributed design and manufacturing processes that seamlessly integrate both virtual resources such as CAD systems as well as physical resources for example, additive manufacturing machines.

We refer to this new model and emergent paradigm as Cloud-Based Design and Manufacturing (CBDM). CBDM refers to a product development model aimed at on-demand resource sharing and scalability through infrastructure as a service hardware and software utilization of product design and manufacturing process resources. Consequently, we propose the following definition for cloud-based design and manufacturing:

*Cloud-Based Design and Manufacturing refers to a product development model that enables collective open innovation and rapid product development with minimum costs through social networking and*

*crowd-sourcing platforms coupled with shared service pools of design, manufacturing resources and components.*

Figure 3 illustrates the concepts underlying the foundations and principles of CBDM systems aligned with our proposed definition thereof.

At this point, it is noteworthy to explain the use of the term ‘Cloud’. Communication and network engineers have traditionally encapsulated the inherent interconnection complexity of networks with ‘cloud diagrams’. In essence, a network of any reasonable size is too complex to draw on a diagram. Consequently, cloud diagrams are used to hide the interconnect complexity while simultaneously revealing the primary details of a particular network diagram. As seen from Figure 3, the Internet communication ‘cloud’ forms the basic and required ‘underlay’ network for any CBDM system in general. As stated previously, CBDM technologies are enabled by Internet-based information and communication technologies. This dependency is represented by illustrating CBDM as an ‘overlay’ in Figure 3. Moreover, Figure 3 seeks to illustrate the overall and basic interconnectivity of the primary

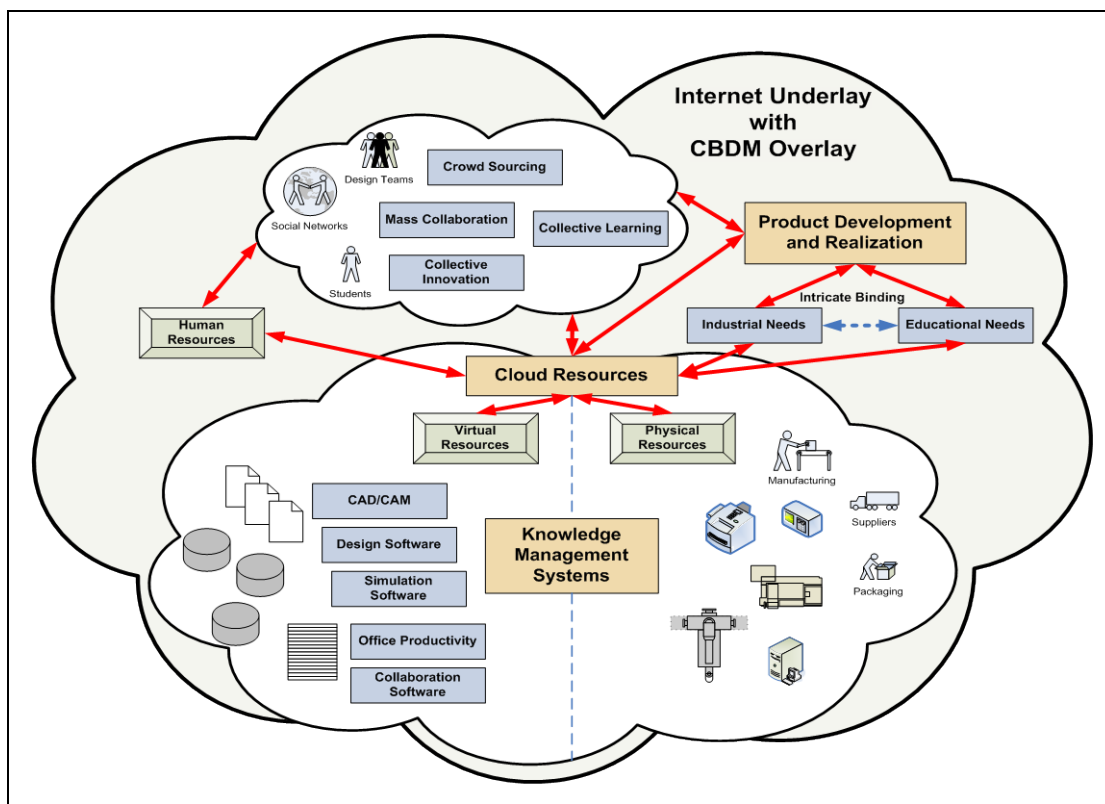

Figure 3: The CBDM concept.

elements of a CBDM system. For example, the human resources of a CBDM system form their own ‘human-centric network’, which is represented by design teams, social networks, and students, just to name a few. Likewise, the cloud resources, which include human, virtual and physical resources, are illustrated along with their appropriate ‘partitions’. One of the primary goals of CBDM is to enable efficient product development and realization processes. Hence, appropriate interconnections are established between this goal and the basic partitions of the diagram. Further, one should observe the ‘needs’ of the product development and realization process, namely, industrial needs and educational needs. These two sectors comprise the basic categories of entities who ‘needs’ the CBDM functionality. Moreover, industrial needs and educational needs are, in general, *intricately bound*. Industry will use CBDM technology to produce raw goods and services. Obviously, industry depends on educational entities for the following: (1) to educate students on the basic principles and foundations of CBDM systems in order to accomplish their economic goals and (2) to conduct cutting-edge research and development on the underlying details of CBDM systems. Hence, the educational and industrial entities are intricately bound.

### **An Integrated Design and Manufacture Infrastructure for CBDM**

As a first step toward realizing our goals and vision of CBDM, a corresponding architecture needs to be developed. Over the past two years, researchers at Georgia Tech have adapted their work on remote laboratories [15,16,17] to the field of remote hardware and software resources, in order to create an appropriate foundation that models our vision of CBDM systems. An overview of this CBDM infrastructure and its prototype implementation is presented in the following subsections.

#### ***An Infrastructure for Distributed Collaborative Design and Manufacturing Inspired by the Cloud Computing Paradigm***

In general, an infrastructure is a system of assets such as physical components, human resources, operational processes, and organizational structures required to facilitate a particular set of outcomes. For example, a country’s transportation infrastructure facilitates the delivery of raw goods, in

which raw goods are used to produce products, in which products are then delivered to consumers. Naively, one might assume that the transportation infrastructure consists simply of a country’s network of roadways. However, the transportation infrastructure is more complex than just the roadway network. Instead, it consists of the roadway network system, the system of organizations producing raw goods, the system of organizations who produce products from the raw goods, the organizations who deliver the products and raw goods, and the consumers of the final product. It is easy to argue that an infrastructure is a complex “System of systems”. One particular concept common to any infrastructure is that the infrastructure’s system of assets are employed for the purpose of combining problem holders with problem solvers to produce some set of outcomes that facilitate the solution for the underlying need implied by the necessity of the infrastructure. An infrastructure is a collection (system) of assets that collectively produce a set of desired outcomes, which would not be attainable by any particular asset alone. The value added by the infrastructure is determined by the interconnection of its assets, which is the interconnection between problem holders and problem solvers.

We have developed a distributed infrastructure with centralized interfacing system (DICIS) model for CBDM, which is illustrated in Figure 4.

The components within DICIS include all user interfacing components (i.e. Web browsers), communications and security components (the Internet and enterprise firewall systems), human assets (users, producers, consumers, managers, etc), and the actual manufacturing process assets. Note, that manufacturing process assets (MPA) include software components such as CAD tools and packages as well as physical components such as 3D printers, milling machines, electrical prototyping boards, and robotic equipment. Even though a “pure” cloud computing framework normally only represents software systems, the DICIS model for our CBDM includes both virtual resources (i.e. software, computer hardware, etc) as well as physical and human resources such as the equipment listed above. In essence, the DICIS model and its implementation as a CBDM system can be viewed as an integrated design and manufacturing infrastructure, which can support industrial applications as well as educational needs such as computer-centric laboratory coursework and research.

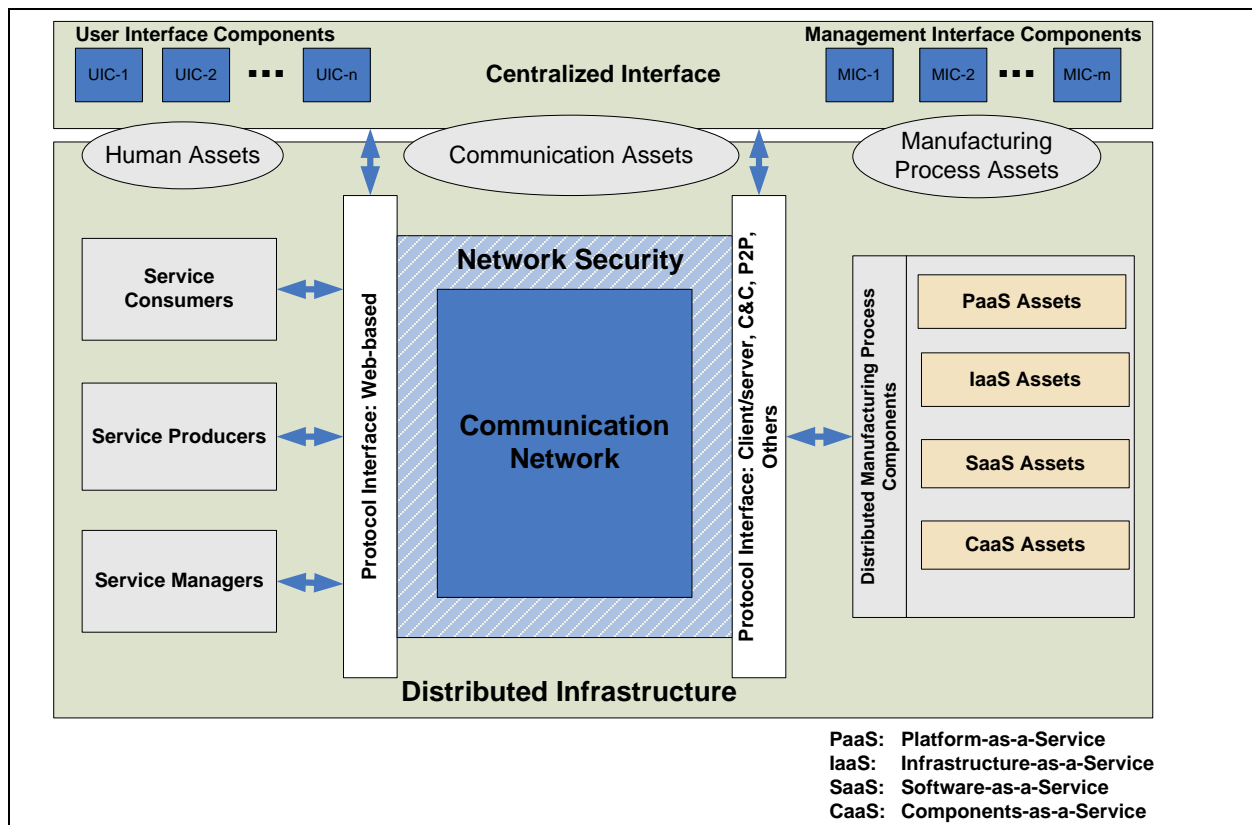

Figure 4: The DICIS model for CBDM.

The DICIS model categorizes CBDM assets into three primary groups: 1) Human Assets, 2) Communication Assets, and 3) Manufacturing Process Assets. Further, human, communication, and manufacturing process assets are bound to both the centralized interface (CI) and the distributed infrastructure (DI). The distributed infrastructure incorporates the primary physical, virtual, and human resources of the CBDM. However, the centralized interface, which includes two primary groups of components referred to as the user interface components (UIC) and management interface components (MIC), provides the resources that glue the system together.

The DICIS model considers three human asset categories: (1) service consumers, (2) service producers, and (2) service managers. Service consumers utilize the services offered by the CBDM. Service consumers include, for example, students participating in distributed design and manufacturing projects, researchers/engineers investigating a new design prototypes, or companies with geographically distributed manufacturing shops that need to manufacture the components of a new product. Service producers provide human resources in term

of intellectual capital and labor that result in provisioning of useful services. For example, a laboratory assistant or production manager could be a service producer who installs a new set of devices and equipment into the CBDM and integrates these components to form a new consumer service. An example could be a remote manufacturing site that is installing a new 3D printer and milling machine into the CBDM that should be used by human assets (consumers) of the CBDM. Service managers administer the various resources in the CBDM, depending on the scope of their management roles. Service managers perform operations such as creating new user accounts, assigning user roles, scheduling projects, installing new CBDM resources, and scheduling system maintenance, just to name a few.

In the most general sense, service producers and service managers are problem solvers, whereas service consumers are problem holders. However, service producers and service managers can be problem holders that seek services of other service producers and service managers. Further, a particular user can simultaneously be a service consumer, producer, and/or manager, depending on the user's

role with respect to the system as a whole. For example, consider the user Alice. Alice can be a student participating in project A, a producer for project B, and a manager of project C.

The communication assets of DICIS are comprised of four primary components: (1) communication network, (2) network security, (3) human asset service communication interface (SCI), and (4) manufacturing process asset service communication interface. We assume that the communication network is based on the Internet Protocol (IP) such that standardized, ubiquitous, Internet-based communications take place. The network security component encapsulates the communication network component, which reflects the idea that securability is needed but also that in modern day enterprise network systems, it already exists in several forms, but most notably in the form of firewall systems. In order to capitalize on the ubiquitous Web, the human asset SCI uses Web based protocols. Using Web based protocols such as the Hyper-Text Transport Protocol (HTTP) between human assets and the centralized interface will minimize CBDM deployment costs as it removes the need to develop specialized interface software for system utilization. However, the manufacturing process asset SCI can be more diverse, and different protocols such as client-server, command and control, and peer-to-peer protocols can be used, depending on the particular requirements of a given subset of the CBDM.

The manufacturing process assets of the DICIS model consist of hardware (physical) and software (virtual) design and manufacturing resources. Our current CBDM under investigation, which is an implementation of the DICIS model, consists of a heterogeneous hardware and software environment, and it supports manufacturing and laboratory hardware devices such as milling machines, lathes, laser cutters, 3D printers (3DP), and do-it-yourself (DIY) 3D printers.

For the software systems, our CBDM utilizes various computer-aided manufacturing (CAM) technologies, which are software systems that convert digital models of parts designed by our integrated CAD tools into machine-based fabrication instructions. Moreover, we are developing a range of software applications for design and manufacturing activities, as well as system and resource

management. Some of these software applications include the following:

1. Design Software: The commercial Dassault Systèmes suite of design and analysis tools such as CATIA and Simulia, which enable high-end CAD and analysis capabilities, as well as collaboration.
2. Manufacturing: A set of software tools are being developed to aid in the transition from CAD models to parts fabricated with additive manufacturing (AM) technology.
  - a. AM-Select: A front-end software service enabling students to interactively identify feasible AM systems and materials available within our CBDM.
  - b. AM-Advertise: Software capability allowing independent manufacturing sub-systems to advertise service availability and associated service usage parameters.
  - c. AM-Request: Software capability allowing service consumers to request AM services and other CBDM resources from service producers.
  - d. AM-Manufacturable: Software capability that queries the CBDM for questions such as whether a specific part is manufacturable on a specific machine (i.e., a specific 3DP service producer) and, if not, what properties of the part prevent manufacture.
  - e. AM-DFAM: Design for additive manufacturing software services. tutor and example database.
  - f. AM-Teacher: Learning content, tutorials, service ‘wizards’, videos, and other educational content.

### ***Basic overview of the CBDM workflow.***

A few basic details of our CBDM architecture are illustrated in Figure 5. As shown in Figure 5, the CBDM system consists of a centralized interfacing server (CIS). The current version our CBDM uses a CIS platform that is based on the Sakai learning management system [23]. From Figure 5, several geographically dispersed users (i.e., students) who are collaborating on a design project and are utilizing services of the CBDM such as CAD design tools, 3D printers, and CNC machines. The CIS also provides applications for resource management and scheduling, as well as the AM-manufacturing



software. Once designs are ready for prototyping, STL files generated by the CAD tool are submitted to the CBDM 3DP service framework. Further, for parts that are to be fabricated in metal, a design file (i.e., STL files) can be sent to a milling machine, which is controlled via software running on a milling machine PC (server), for the actual production of the end product. Note that the user interface is composed of Web-browser interfaces into the CAD software as well as the 3D printing and milling machine controller software.

Figures 6 and 7 will be used to further explain the CBDM process. Figure 6 illustrates how our CBDM provides distributed and collaborative design and manufacturing services to three engineers. From Figure 6, two of the engineers are working locally while the third is located at a distant site. Real-time collaboration is enabled via video tele-collaboration services. Further, the three engineers are able to access the CAD design software, but not simultaneously. Instead, CAD ‘control’ is transferred on-demand to any give designer in the collaborative design session by way of issuing a ‘transfer input control’ request to the software application. Figure 7 shows how the design file from

Figure 6 is transferred to a remote 3D printer within the CBDM. In essence, once the collaborating engineers from Figure 6 have completed their design and are ready to develop an AM prototype of the design, other software within the CBDM such as AM-Select is used to transfer design files from the CAD service to the 3D printer service.

In the first three sections of this paper, we have presented a brief overview of the highly topical paradigm of cloud computing, addressed a new research direction of applying cloud computing to design and manufacturing (CBDM) activities, and discussed both an architecture for CBDM as well as a prototype implementation we have been experimenting with for the past year. Now, it is time to tie our research to education and embed it into our classroom activities. While conducting cutting edge research is of key importance to keep our nation at the forefront of technological advancement, we also need to be very concerned about conveying our expertise to the next generation of engineers. Consequently, we always look for ways that allow us to incorporate our research into educational activities. An overview of one such endeavor is presented in this section.

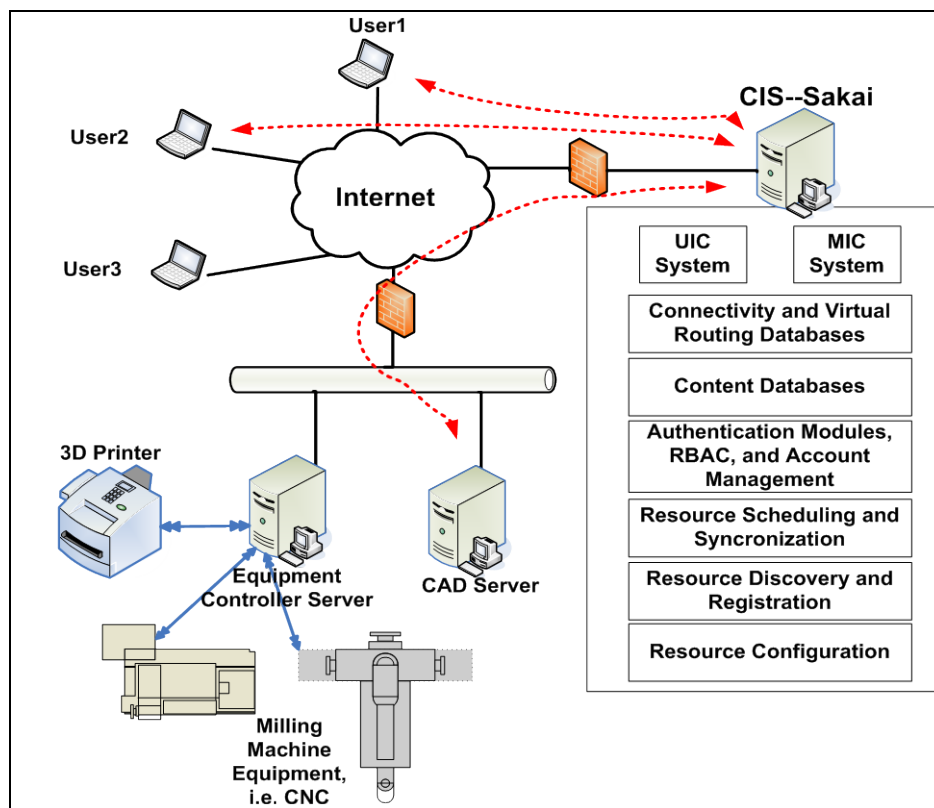

Figure 5: Workflow illustration of our CBDM system.

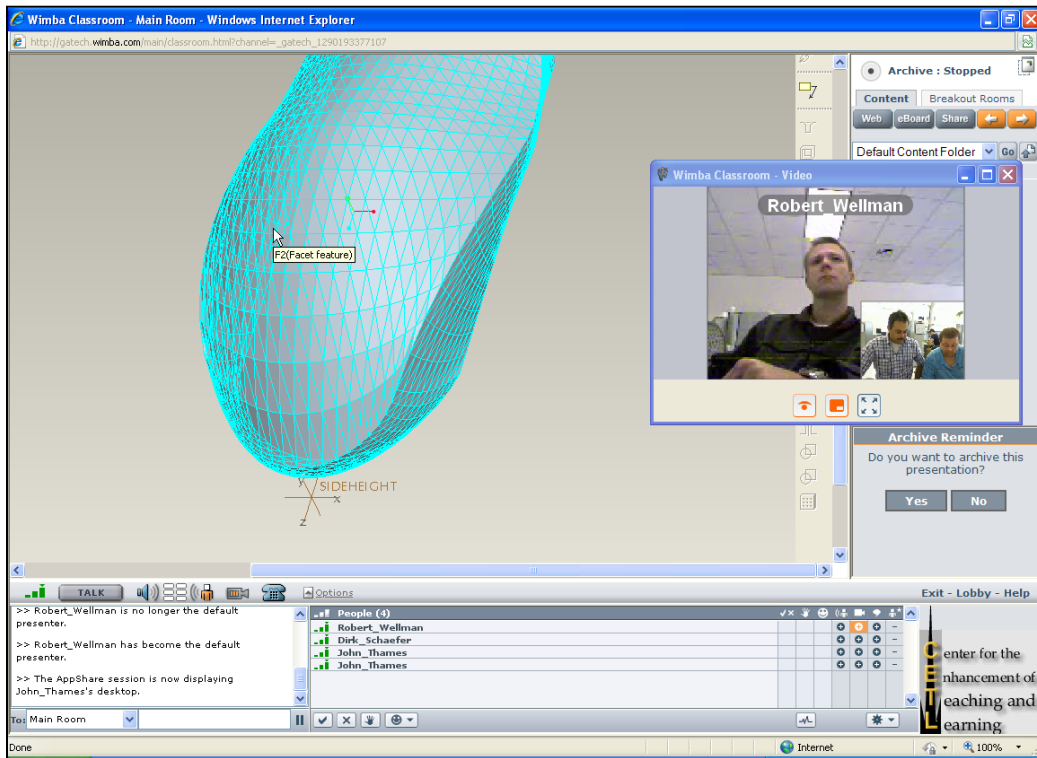

Figure 6: Engineers collaborating on the design of an ergonomic computer mouse via our CBDM system.

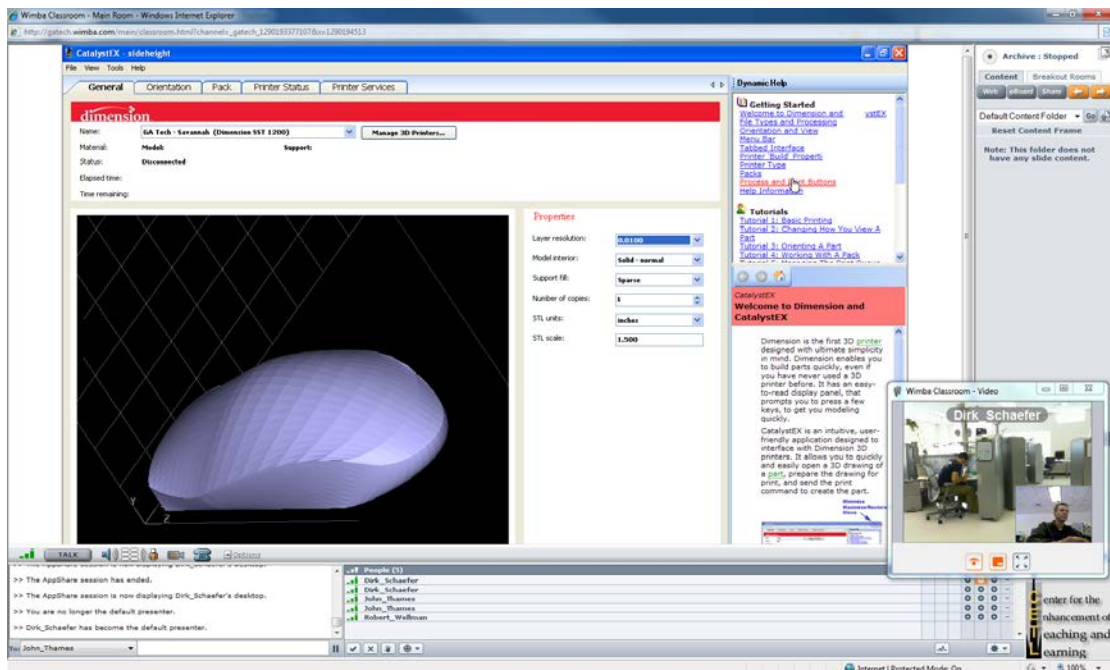

Figure 7: Sending a design file to a 3D printer resource within our CBDM system.

## CBDM in ME6102 Designing Open Engineering Systems (Spring 2012)

*ME6102 Designing Open Engineering Systems* is a graduate level design course offered at the Georgia Institute of Technology. It is taken by students with diverse backgrounds from a variety of engineering and science disciplines. The course is offered in both live and distance learning modes. The student body is comprised of participants from the Georgia Tech Atlanta, Savannah, and Lorraine (France) campuses as well as distance-learning students from across the US and abroad. We expect students taking this course to have been introduced to an approach to systems design [9] and participated in a group design experience, for example, capstone. A detailed overview of the educational framework of this course has been presented in [10].

As mentioned before, our engineering design course is offered in both an on-campus as well as a distance learning setting. While such a distributed setup is rather unusual for design education (and hence not well documented), it is highly conducive to our efforts of embedding highly topical aspects, such as cloud-based design and manufacturing, crowd-sourcing, mass collaboration, and distributed virtual product creation in our course and effectively conveys that we actually do what we preach – and what is common practice in the real world [22]. Hence, we deem it to be appropriate to share information on our course-related IT infrastructure, which includes our CBDM presented in the previous section.

An educational entity needs appropriate technology and infrastructure to facilitate collaborative and collective learning in a distributed environment. Figure 8 illustrates, at a high-level, certain aspects of the distance learning environment that has been established at the Georgia Institute of Technology. Georgia Tech has its primary facilities located in Atlanta, GA (GTA) with regional facilities located in Savannah, GA (GTS). Further, Georgia Tech has international facilities located in Lorraine, France (GTL) and Ireland as well as other micro-sites/facilities both in the US and abroad. Two primary modes of education are in place: synchronous education and asynchronous education.

Synchronous operations refer to activities whereby members of the learning organization/community (instructors, students, researchers, etc.) meet at

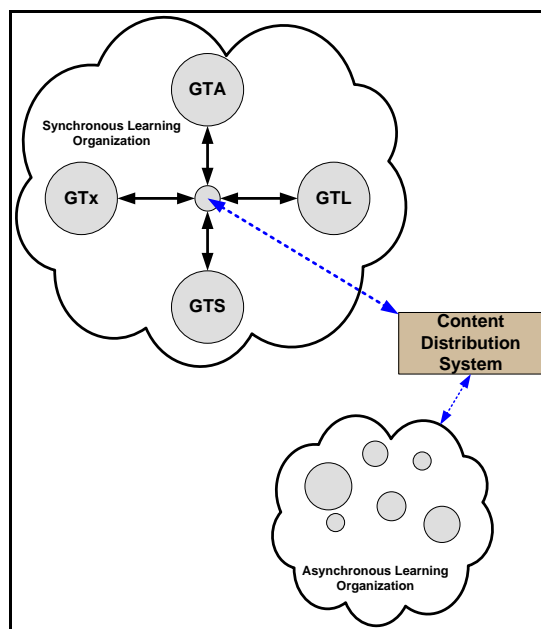

Figure 8: Distance learning environment.

scheduled times either in person or virtually. Virtual attendance in synchronous mode is provided by advanced video-tele-collaboration (VTC) technologies whereby high-definition video and audio is transmitted over Internet-based ICT. Some of these technologies include Tandberg/Polycom/ Cisco video codec and tele-presence systems. Classroom activities are virtually interconnected via these types of ICT systems such that members of the geographically distributed learning organization can participate. Because ICT technologies are used for the delivery of real-time (synchronous) coursework, opportunities exist for content capture and archival, which is then re-distributed via asynchronous education channels. As such, new opportunities of online-education exist, as compared to its current form. Asynchronous learning allows students to retrieve all aspects of archived coursework such as digitally recorded lecture, tutorials, and any form of digitized materials.

In essence, a content distribution system (CDS) is utilized for the delivery and consumption of our synchronous and asynchronous constituents. The concepts illustrated in Figure 8 depict how the geographically separated entities in the “Synchronous Learning Organization” (SLO) interconnect for the delivery of educational content. During the course of SLO delivery, content is captured, archived and managed. Content is then accessed at a later time by entities of the “Asynchronous Learning Organization” (ALO).

ME6102 students consist of both synchronous *and* asynchronous students. We refer to coursework and teaching provided simultaneously to both synchronous and asynchronous students as ‘blended-mode’ content delivery.

A learning management system (LMS) is a key ICT mechanism enabling efficient utilization of educational material (content). Further, we believe it is a fundamental component needed for the realization of advanced distance learning environments. LMS are used by many universities, especially those who provide online education programs. The most common utilization of LMS by educational institutes of today is focused on the organization of coursework materials such as lecture notes, tutorials, audio, and video. However, we are working towards advanced LMS that provide a centralized interface into *all* aspects of the university’s learning and research environment. Figure 9 provides a conceptual overview of our content distribution system.

Before continuing our discussion, please take note, that some components in our CDS, as shown in Figure 9, are in production while others are in prototype states and have not been deployed on a large-scale content delivery basis at this time. In particular, the CloudLabs and ManuClouds systems are prototypes currently under investigation as part of a large-scale research endeavor. A number of systems within our CloudLabs have been developed for a number of mechanical engineering laboratory classes. Moreover, these CloudLabs deployments and their educational benefits and deficiencies have been assessed by students who took the associated coursework [15]. However, all other components in Figure 9 are utilized in production within our content distribution system.

Our LMS, which we call *Tsquare*, is built on the Sakai learning management framework [23]. *Tsquare* is a modular and easily-extensible system that provides traditional LMS functionality. Users of the system, which comprise of two primary groups being content producers and content consumers, have access to coursework content and are capable of building their own project-specific collaboration sites with just a few clicks of the mouse. The system’s Web 2.0 based interface, which is shown from one perspective in Figure 10, contains numerous features and technologies such as text-

audio-video chat, wikis, blogs, RSS feeds, scheduling applications, file archiving, email, and remote desktop sharing.

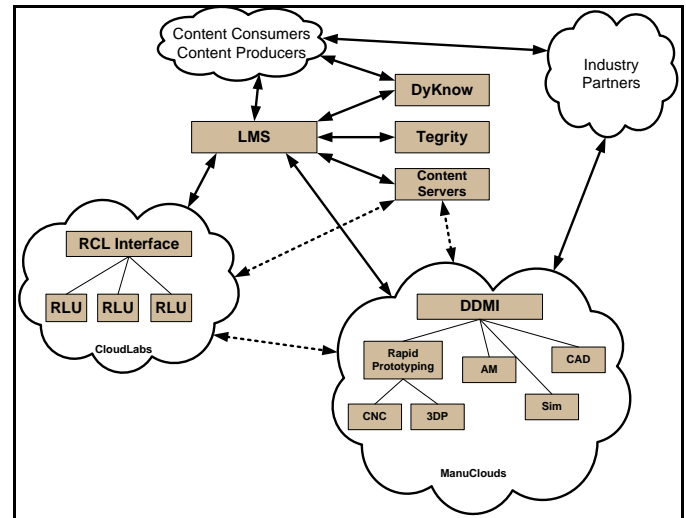

Figure 9: Content distribution system.

Both synchronous and asynchronous students access course content via the LMS. Asynchronous students, access the archived video lectures via the LMS or, in certain cases, through a direct ICT link into the digital lecture archives. Both groups of students as well as all others involved in the learning organization use the LMS as *one* particular centralized tool for distributed collaboration. Collaborative design tools used in our learning organization consist of, video chat sessions, multi-point remote desktop sharing (i.e., one desktop ‘controlled’ by many participants such as designing an artifact with CAD software), digital white boards for concept sketching, and interactive mind mapping tools, to name a few. A nice feature provided by our LMS is that these interactive-at-a-distance collaboration sessions can be digitally recorded and archived for retrieval at a later time.

One feature of educational content creation is its various forms and *simultaneous* capture via digital recording, enabling the content to be archived for later reference by those who created it *and* by anyone else who needs it. In particular, anyone in the learning organization can be content producers and/or content consumers. This aspect facilitates a very rich Web of knowledge (content) creation, usage, and ‘cyclic re-usage’—that is to say, the continual reuse of content as time goes on, which has many benefits if used appropriately.

One simple example of cyclic reuse is the formation of personalized or customized education with ‘content chunks’—the idea of “pull a lecture from here and a lecture from there and a book from here and a paper from there...and put them all together”. Mass-customization, which is yet another direct product of advanced ICT and strongly related to mass collaboration and collective learning, is generally a process of interconnecting the pieces of ‘something’ to produce ‘something else’. In the case of innovative education, mass-customization of education will consist of interconnecting pieces of educational material—content chunks of archived lecture and other digital materials along with non-archived educational artifacts—to produce a final product of personalized education.

The discussion thus far in this section has revolved around technologies we use in our distance learning setting. However, students participating in distance learning environments for collaborative design can be quite inventive when put to the test. During ME6102 we influence—rather, strategically force—students to go off on their own and search for additional technologies that are available and *put things together on their own* to aid in distributed collaborative product creation. A few success stories

of the innovative techniques our students have achieved included the use of tools such as Google Docs, Google Groups, Google Sites, Wiggio, and Skype. Some have used the ‘Drupal Content Management System’ to build out their own Web-based collaboration tools. In terms of using Skype, one group integrated a multi-point live video session that illustrated a tri-axial robotics demonstration to a group of geographically separated design collaborators. The illustration of our LMS interface shown in Figure 10 is actually a result where students learned how to use the site-building features of our Tsquare LMS to pull in data from other sources, such as Google Docs.

In the spring semester of 2012, our CBDM will be utilized on a larger scale for the official ME6102 class project for the first time. Students from across the country as well as from France will work on a collaborative design project that includes, among other challenges, the utilization of CAD software and the production of artifact prototypes using a 3D printer. Both digital and physical equipment resources will be at different geographical locations. Although we have previously assessed the efficacies of CBDM systems in the form of remote laboratories[15], the enhanced features of our

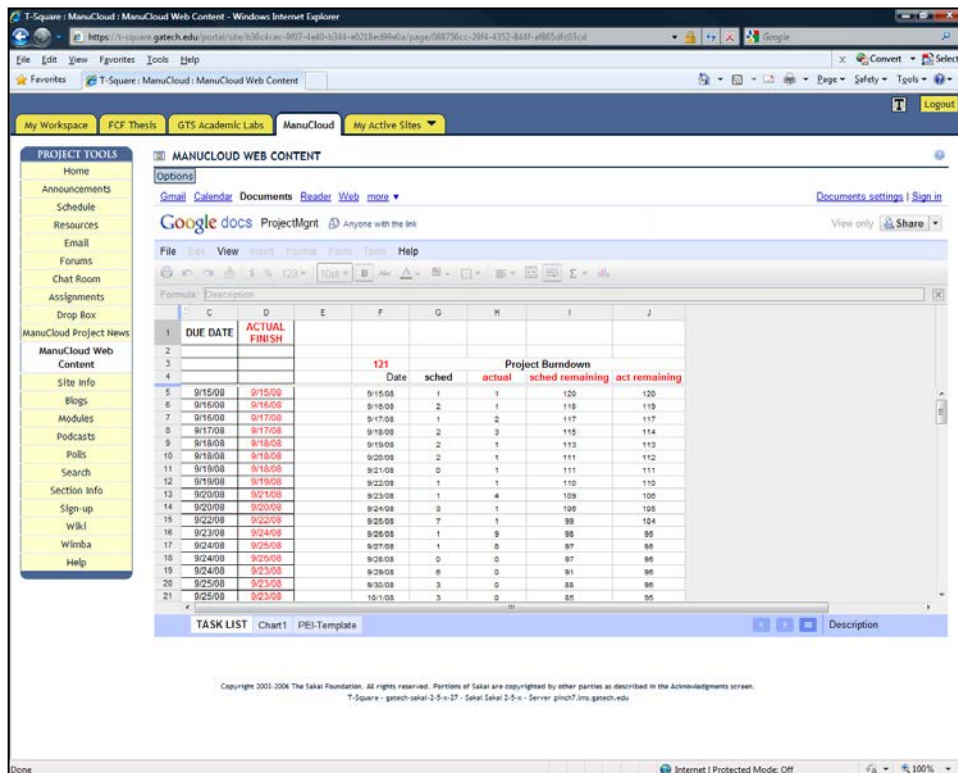

Figure 10: Perspective of the Tsquare LMS.

current CBDM require new assessments to ensure that the students' educational goals and outcomes are achieved.

It is our intention to investigate how students initially respond to the task of designing a product and manufacturing a prototype in a distributed setting that integrates virtual with physical resources and how they adapt to it as the project phase progresses. In addition, we plan on experimenting with various formats of familiarizing the students with our CBDM environment, including videos, online tutorials, and associated assessment tools. At the current work-in-progress stage, it is important to investigate the instructional techniques required to introduce the students to the very rich IT environment without losing the focus on the design and manufacture specific technical details of the course.

### Closing

In this paper, we have presented an overview of our endeavors to expand the paradigm of cloud computing to the domain of engineering design and manufacture. Both a working definition and initial vision for Cloud Based Design and Manufacture (CBDM) have been suggested and an IT infrastructure to support our CBDM research activities has been developed. In addition, we have explained how we are utilizing CBDM research in the context of a distance learning engineering design course. As for future work, a roadmap outlining key research issues with regard to realizing CBDM and its impact on the computer-aided product realization process is being prepared.

### Acknowledgements

We thank our industrial collaboration partners MSC Software, Procter and Gamble, John Deere, Hewlett Packard, The RBR Group, and Georgia Tech's DLPE, who, over the course of the past three years, have actively supported our work in ME6102 through guest lectures, sponsored projects, or donated hardware and software.

### References

1. Armbrust, M., Fox, A., Griffith, R., Joseph, A. D., Katz, R., Konwinski, A., Lee, D., Patterson, Rabkin, A., Stoica, I., & Zaharia, M., 2010, Above the Clouds: A View of

Cloud Computing, Communications of the ACM.

2. R. Buyya et al., 2008, Market-oriented cloud computing: vision, hype, and reality for delivering it services as computing utilities.
3. NIST definition, 2011, The NIST definition of cloud computing.
4. Vaquero, L. M., Merino L.R., Caceres, J., & Lindner, M., 2009, A break in the clouds: towards a cloud definition, ACM SIGCOMM Computer Communication Review archive.
5. Schaefer, D. (2011): "Take E-CAD to the Cloud?" In: Control Design. ISSN 1094-3366, November, 2011, pp.44-45 and online controlcesign.com
6. Wikipedia: Cloud Computing, [http://en.wikipedia.org/wiki/File:Cloud\\_computing.svg](http://en.wikipedia.org/wiki/File:Cloud_computing.svg), retrieved on 12/13/2011.
7. Nan, X., He, Y., & Guan, L, 2011, optimal resource allocation for multimedia cloud based on queueing model.
8. Cheng, Y., Zhao, D., Hu, A.R., Luo, Y.L., Tao, F., & Zhang, L., 2011, multi-view models for cost constitution of cloud service in cloud manufacturing system, Communications in computer and information science.
9. Pahl, G., Beitz, W., Feldhusen, J. and K.-H. Grote (2007), Engineering Design – A Systematic Approach. Springer.
10. Schaefer, D., Panchal, J., Haroon, S., and F. Mistree (2011), Design Education for the world of near tomorrow: Empowering students to learn how to learn. 2011 ASEE Annual Conference and Exposition, Vancouver, BC, Canada, June 2011.
11. World Wide Web, Sakai—A community of educators collaborating to create open software that advances teaching, learning, and research, <http://sakaiproject.org>, accessed July 4, 2011.

12. Narasimhan, B. and Nichols, R., 2011, *State of Cloud Applications and Platforms: The Cloud Adopters' View*, Computer, Vol. 44, Number 3, pp. 24-28, IEEE Computer Society
13. Banaerjee, P., Bash, C., Friedrich, R., Goldsack, P., Huberman, B., Manley, J., Patel, C., Ranganathan, P., and Veitch, A., 2011, *Everything as a Service: Powering the New Information Economy*, Computer, Vol. 44, Number 3, pp. 36-43, IEEE Computer Society
14. Morgan Stanley, *The Mobile Internet Report*, 2009, pp. 84-125
15. Hyder, A.C. : "Design and Implementation of Remotely Controlled Laboratory Experiments", MS Thesis, Georgia Institute of Technology, School of Mechanical Engineering, May 2010.
16. Thames, J.L., Hyder, A.C., Wellmann, R., and D. Schaefer: "An Information Technology Infrastructure for Internet-Enabled Remote and Portable Laboratories", 2009 ASME International Design Engineering Technical Conferences and Computers and Information in Engineering Conferences, IDETC/CIE 2009, San Diego, CA, August 30-September 2, 2009.
17. Thames, J.L., Hyder, A.C., Wellmann, R., Schaefer, D. and R. Abler: "Architectures and Design Methodologies for Scalable and Sustainable Remote Laboratory Infrastructures". In: *Azad, Auer, Judson (Eds.), Internet Accessible Remote Laboratories: Scalable E-Learning Tools for Engineering and Science Disciplines*, IGI Publishing, 2011.
18. Ulrich, K.T., & Eppinger, S.D., 2007, *Product Design and Development*, 4th Edition, McGraw-Hill, New York.
19. AutoDesk, [www.autodesk.com](http://www.autodesk.com), 2011
20. Fujitsu, "Fujitsu announces 'Engineering Cloud' for new era in manufacturing", <http://www.fujitsu.com/global/news/pr/archives/month/2011/20110621-02.html>, 2011
21. DARPA Tactical Technology Office, *Adaptive Vehicle Make Program*, [http://www.darpa.mil/Our\\_Work/TTO/Programs/Adaptive\\_Vehicle\\_Make\\_\(AVM\).aspx](http://www.darpa.mil/Our_Work/TTO/Programs/Adaptive_Vehicle_Make_(AVM).aspx)
22. Rippel, M., Panchal, J. H., Schaefer, D., and Mistree, F., 2009, "Fostering Collaborative Learning and Educational Mass Customization in a Graduate Level Engineering Design Course," International Journal of Engineering Education, in print.
23. Sakai Software, <http://sakaiproject.org/portal>

### Biographical Information

Dirk Schaefer is an Assistant Professor at the George W. Woodruff School of Mechanical Engineering at Georgia Institute of Technology. Prior to joining Georgia Tech, Schaefer was a Lecturer in the School of Engineering at Durham University, UK. During his time at Durham, he earned a Postgraduate Certificate in "Teaching and Learning in Higher Education." He joined Durham from a Senior Research Associate position at the University of Stuttgart, Germany, where he earned his Ph.D. in computer science. Over the past 10 years, Schaefer has been conducting research on product modeling, variant design, product lifecycle management, design-with-manufacture integration, standardized product data exchange, and digital and virtual engineering. His current research focus concerns the highly topical area of cross-disciplinary integrated design of mechatronic systems. Schaefer has published approximately 100 technical papers in journals, books, and conference proceedings on computer-aided engineering and design, as well as engineering education. Schaefer is a registered professional European Engineer (Eur Ing), a Chartered Engineer (CEng), a Chartered IT-Professional (CITP), a Fellow of the Higher Education Academy (FHEA) in the UK, and a registered International Engineering Educator (Ing-Paed IGIP).

Lane Thames is a Ph.D. candidate (ABD) in electrical and computer engineering at the Georgia Institute of Technology. He obtained his B.S. in computer engineering with Highest Honors in Dec. 2003 followed by his M.S. in electrical and computer engineering in May 2006, both from Georgia Tech. His core research is centered around three primary thrusts: distributed active-response firewall systems and architectures enabling globalized Internet security, detection of computer and network attacks using computational intelligence and hybrid intelligence systems, and high-speed, low-power hardware algorithms for the multidimensional packet classification problem. His professional interests are diverse and revolve around the intersection of several topics, including high-speed internet protocol networking and computer communications, internet security, engineering education, computational intelligence systems, knowledge discovery in data, largescale distributed systems integration, and collaboration platforms via generalized cloud computing service models. Thames holds a full-time staff position as Systems Analyst III for Georgia Tech, while concurrently completing his Ph.D. Thames has held several positions at Georgia Tech including Lead Teaching Assistant as an undergraduate and Graduate Research Assistant during the first two years of his graduate education. Before taking his current staff position at Georgia Tech, Thames spent 18 months working for VeriSign's Communication Services Division. Thames also serves as a research collaborator and lead infrastructure/systems architect for Dr. Dirk Schaefer's initiative on remotely controlled physical laboratory experiments and collaborative design education.

Robert Wellman is the Manager of the Information Technology Department at Georgia Tech's Savannah campus. Wellman earned his bachelor's of science in computer engineering from the Georgia Institute of Technology. Upon completion of his degree, Wellman accepted a position in the IT Department at Georgia Tech Savannah. His responsibilities on campus cover a wide range of technologies including infrastructure design and support (network, virtualizations, and Windows/Linux servers), desktop support (Windows/Linux/Mac workstations), video conferencing design and support (infrastructure devices and endpoints), and laboratory support (electronic testing equipment, load frames, etc). Research interest areas include

collaborative and distributed learning systems and frameworks and network security.

Dazhong Wu is a Ph.D. student in the G.W.Woodruff School of Mechanical Engineering at Georgia Tech. He received his B.S. and M.S. degree in mechanical engineering from Hunan University and Shanghai Jiao Tong University in 2004 and 2007, respectively. His research interest is cloud-based design and manufacturing. Since 2010, he has been revitalizing the ASME Savannah section, as the Chair of the ASME Savannah.

David W. Rosen is a Professor and Associate Chair for Administration in the School of Mechanical Engineering at the Georgia Institute of Technology. He is Director of the Rapid Prototyping & Manufacturing Institute at Georgia Tech. He received his Ph.D. at the University of Massachusetts in 1992 in Mechanical Engineering. His research interests include computer-aided design, additive manufacturing, and design methodology. He has industry experience, working as a software engineer at Computervision Corp. and a Visiting Research Scientist at Ford Research Laboratories. He is a Fellow of ASME and has served on the ASME Computers and Information in Engineering Division Executive Committee.